

INSPIRAL



MEDICAL GAS SYSTEMS
2020

The logo for INSPITAL Medical Gas Systems is enclosed in a black rectangular border. The word "INSPIRAL" is written in a bold, sans-serif font, with the "I" and "A" in teal and the "N", "S", "P", "I", "R", and "L" in dark grey. Below it, the words "MEDICAL GAS SYSTEMS" are written in a smaller, dark grey, sans-serif font.

INSPIRAL

MEDICAL GAS SYSTEMS

INSPIRAL Medical Gas Stations & Control Units

INSPIRAL offers complete solution for the medical gas system of hospitals. All the system consist of medical gas generators, manifolds, pipeline system, area control units, alarm systems, monitoring screens and the final gas outlets in Operating Theatres, ICU's and patient rooms

Contents

Central Gas Stations	06
Manifold System with Double Regulator	08
Area Gas Control Panels	11
Alarm Panels	12
Medical Gas Alarm Management System	12
Medical Vacuum Station	14
Vacuum Pumps	18
Mini Vacuum Station	19
Anaesthetic Gas Scavenging System	19
Medical Air	20
Oxygen Production Systems	25
Cryogenic Oxygen Stations	26
<hr/>	
Copper Pipes And Accessories	
Copper Tubes	28
Fittings	29
Medical Gas Outlets	30
<hr/>	
Patient Bed Head Units and Pendants	
Patient Bed Head Units	32
Pendants	36
<hr/>	
Medical Gas Outlets and Accessories	
Outlet Boxes	40
Probes	41
<hr/>	
Respiration Equipment	
Flowmeters	42
Regulators	45
Venturi System Suction Units	46
<hr/>	
Suction Accessories	
Reusable Canister	50
Central Vacuum System	53
<hr/>	
Nurse Calling Systems and Testing Equipment	
Nurse Calling Systems	54
Testing Equipment	59



INSPI TAL MEDICAL GAS STATIONS & CONTROL UNITS

INSPI TAL offers complete solution for the medical gas system of hospitals.

All the system consist of medical gas generators, manifolds, pipeline system, area control units, alarm systems, monitoring screens and the final gas outlets in Operating Theatres, ICU's and patient rooms.

CENTRAL GAS STATIONS & MANIFOLDS

INSPI TAL central gas stations are designed to supply continuous medical gas from the cylinders to hospital pipeline.

Electronically controlled manifold system reduces the cylinder pressure to required level.

Each station controls one primary and one back up cylinder racks and switches between them without interrupting the continous flow



AREA GAS CONTROL PANELS

INSPITAL Area Gas Control Unit is manufactured to provide isolation of individual floors of medical gases in the hospital.

Area Gas Control Unit includes all features required by the EN ISO 7396-1 and HTM 02-01 standards.

Isolation may be required for installation, maintenance or in case of an emergency

VACUUM STATIONS

Vacuum is an essential requirement of the supply system for medical gases in hospitals.

INSPITAL develops and manufactures fully automatic, stable and highly reliable vacuum stations which are used to aspirate airways in the operating theatres, on ICU and on regular patient rooms

Central Gas Station for O₂, N₂O and CO₂



INSPIRAL central gas stations are designed to supply continuous medical gas oxygen, nitrous oxide, entonox, medical air, carbon dioxide and nitrogen from the cylinders to hospital pipeline. Each station controls one primary and one back up cylinder racks

A two stage regulation system, utilizing separate regulating units for each stage of pressure regulation, offers higher flow rates and smoother flow rate curve.

Station switches to back up system automatically when the pressure of primary rack is dropped.

Station is equipped with non-return valves in order to prevent discharge of the gas in the cylinders during the replacement or in case of leakage from the pipeline.

All pressure data and failure alarms are controlled by the digital control panel.

Medical Gas Plants

Oxygen Station	Model No	GZ71.01	GZ71.02	GZ71.03	GZ71.04	GZ71.05	GZ71.06	GZ71.07
Nitrous oxide Station	Model No	GZ71.10	GZ71.11	GZ71.12	GZ71.13	GZ71.14	GZ71.15	GZ71.16
High Pressure Reducer 150 m ³ /h		-	-	1 pc	1 pc	1 pc	1 pc	1 pc
High Pressure Reducer 40 m ³ /h		1 pc	1 pc	-	-	-	-	-
Cylinder Fixing Chain, Triple		2 pcs	4 pcs	4 pcs	6 pcs	8 pcs	10 pcs	14 pcs
Flexible Connection Pipe		6 pcs	12 pcs	12 pcs	18 pcs	24 pcs	30 pcs	42 pcs
Flexible Connection		2 pcs	4 pcs	4 pcs	6 pcs	8 pcs	10 pcs	14 pcs
Ramp Triple			4 pcs	4 pcs	6 pcs	8 pcs	10 pcs	14 pcs
Discharge Valve		2 pcs						
Oxygen / Nitrous oxide Station Alarm panel		Including the High Pressure Regulators (1 pc)						
Cylinder Quantity on Station		2x3 pcs	2x6 pcs	2x6 pcs	2x9 pcs	2x12 pcs	2x15 pcs	2x21 pcs
Bed Quantity		30	50	30-50	40-70	70-100	100-150	150-200
Total Operating Theatre No. (N2O Central)		3	5	5 - 6	6 - 7	6 - 9	8-12	10-14
Total Station Weight(~)		35 kg	48 kg	58 kg	85 kg	90 kg	120 kg	150 kg

Bed and Operating Room Numbers are given approximately

Emergency Reserve Manifolds

Oxygen Station	Model No	GZ71.09	GZ71.08
Nitrous oxide Station	Model No	GZ71.18	GZ71.17
High Pressure Reducer 40 m ³ /h		1 pc	1 pc
Cylinder Fixing Chain, Triple		2 pcs	2 pcs
Flexible Connection Pipe		4 pcs	6 pcs
Discharge Valve		2 pc	2 pc
Cylinder Quantity on Station		4 pcs	6 pcs
Bed Quantity		5-10	8-12
Total Station Weight(~)		15 kg	18 kg

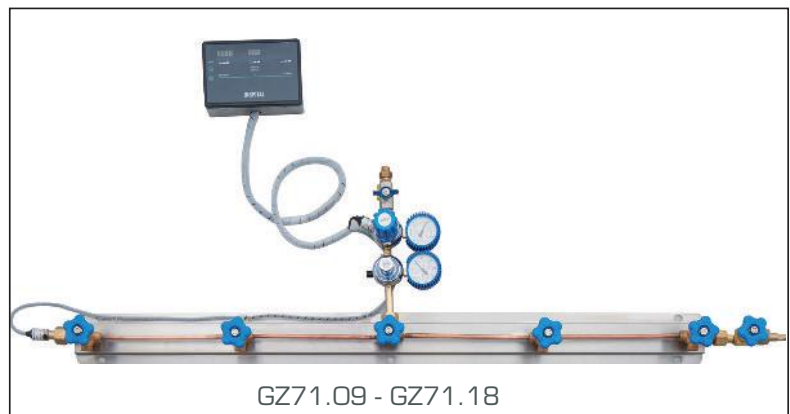

INSPIRAL emergency reserve manifolds includes a two stage regulation system, utilizing separate regulating units for each stage of pressure regulation, offers higher flow rates and a smoother flow rate curve.

Isolation valves are included at each manifold header connection such that one cylinder bank can be online with the other bank closed off during normal system operation, for compliance with HTM O2-O1 standards



Explanation	Model No
W/o alarm 40 m ³ /h	GZ71.20
With alarm 40 m ³ /h	GZ71.21
W/o alarm 150 m ³ /h	GZ71.22
With alarm 150 m ³ /h	GZ71.23

- **Working Mode** : 2 stage, 2 regulators
- **Inlet dia** : 1/2"
- **Outlet dia** : 22 mm
- **Outlet pressure** : 4-6 bar
- **Automation** : Fully Automatic

Manifold System with Double Regulator

Inspiral Automatic Changeover Manifold is designed to provide a continuous supply of oxygen, nitrous oxide, carbon dioxide in healthcare facilities. The manifold consists of two banks of cylinders located on each side of the pressure control assembly. These pressured gases are used in Operation Theatres, Intensive Care Units, Neonatal Care Units, Emergency Rooms and Patient Rooms. Automatic Changeover Manifold are designed and manufactured in compliance with HTM O2-01, MDD 93/42/EEC, EN ISO 7396-1 and ISO 13485 standards

Features

- Special black ABS cover protection against environmental factors
- Designed to ensure continuous and accurate gas supply
- It is designed according to the principle of continuous transfer functionality. So during exchange of the tubes, gas supply won't be interrupted.
- Station capacities depending on the type of gas used and the distance
- For easy access to internal components
- Alarm panel connection placed most easy way
- Fail open in event of power failure to ensure constant supply of gas

Optional Accessories

- Emergency reserve manifold
- Heater Kits
- Isolation valve and test gas outlet
- Spare cylinder racks



Model No	Description
GZ71.47	Positive Pressure Sensor, Max.10 bar
VK40.01	Vacuum Sensor, -1/0 bar
GZ71.49	High Pressure Reducer Sensor, Max.250 bar

Pressure Sensor

- Pressure sensors are used in digital alarm panels to detect high and low pressure

Positive Pressure Transmitter Specs:

- Measurement range : 0 - 250bar
- Signal output : 4 - 20mA
- Mechanical connection : G 1/4 "
- Electrical connection : 2m
- Feeding voltage : 8 - 32V



High Pressure Reducer, Single Regulator

Inspital High Pressure Reducer provide safe pressure reduction of medical gases between the cylinders and the delivery system. It is designed to regulate line pressure between 6 to 4 bar. All components are degreased for oxygen use.

- Oxygen
- Nitrous Oxide
- Carbon dioxide
- Working Mode : 2 stage, 1 regulator
- Inlet dia : 1/2"
- Outlet dia : 22 mm
- Inlet pressure (max) : 220 bar
- Outlet pressure : 4-6 bar

Explanation	Model No
W/o alarm 100 m ³ /h	GZ70.10
With alarm 100 m ³ /h	GZ70.20
W/o alarm 40 m ³ /h	GZ70.30
With alarm 40 m ³ /h	GZ70.40



GZ71.33



GZ71.31

Cylinder Ramp

- Alternative models for connection of 1, 2, 3, 4 or 5 cylinders
- Made of galvanized steel, brass headers and copper pipe

Explanation	Length mm	Model No
Single	180 mm	GZ71.29
Double	330 mm	GZ71.30
Triple	630 mm	GZ71.31
Quadruple	930 mm	GZ71.32
Quintuple	1230 mm	GZ71.33



GZ71.38



GZ71.36

Cylinder Fixing Chain

- Designed to fix the cylinders safely
- Alternative models for connection of 1, 2, 3, 4 or 5 cylinders

Explanation	Length mm	Model No
Single	180 mm	GZ71.34
Double	330 mm	GZ71.35
Triple	630 mm	GZ71.36
Quadruple	930 mm	GZ71.37
Quintuple	1230 mm	GZ71.38

Tail Pipe & Flexible Hose

- Used for connecting the cylinders to cylinder ramp
- Gas specific thread for O₂, N₂O, CO₂ and medical gas cylinders
- Nut diameter: 1/2"



Explanation	Gas Type	Cylinder nut dia	Model No
Tail Pipe 140 cm	Oxygen (bull-nose)	5/8 (Male)	GZ71.39
Tail Pipe 140 cm	Carbondioxide	Ø 21.8 mm, 1/14	GZ71.40
Tail Pipe 140 cm	Oxygen	3/4"	GZ71.41
Tail Pipe 140 cm	Nitrousoxide	3/8"	GZ71.42
Flexible Hose 60 cm	Oxygen (bull-nose)	5/8 (Male)	GZ71.43
Flexible Hose 60 cm	Carbondioxide	Ø 21.8 mm, 1/14	GZ71.44
Flexible Hose 60 cm	Oxygen	3/4"	GZ71.45
Flexible Hose 60 cm	Nitrousoxide	3/8"	GZ71.46
Flexible Hose 60 cm	Oxygen (PIN INDEX)		GZ71.96
Flexible Hose 60 cm	N ₂ O (PIN INDEX)		GZ71.97



Flexible Connection
Model GZ71.94



Discharge Valve
Model GZ71.95

Flexible Connection Pipe

- Designed to connect ramp to ramp and ramp to manifold
- Made of chrome plated copper material
- Compatible with O₂ and N₂O gases

Discharge Valve

- Designed to be used for the gas discharge of medical gas stations
- Compatible with O₂ and N₂O gases
- Made of brass

Medical Gas Ball Valve & Zone Service Unit

- Designed and specially cleaned to use in medical gas system
- Optional lock and nist connection
- %100 corrosion proof design, no painted steel or sacrificial
- Break out plastic window provides safe access in an emergency



Pipe Dia.	Ball Valve With Box Model No	Ball Valve Model No	Working Pressure (bar)
10 mm	GZ71.50	GZ81.50	78
12 mm	GZ71.51	GZ81.51	64
15 mm	GZ71.52	GZ81.52	55
22 mm	GZ71.53	GZ81.53	50
28 mm	GZ71.54	GZ81.54	40
35 mm	GZ71.55	GZ81.55	40
42 mm	GZ71.56	GZ81.56	35
54 mm	GZ71.57	GZ81.57	27
76 mm	GZ81.58	GZ81.59	16

Medical Gas Plants



Stainless Steel

Electrostatic Painted

Electrostatic Painted

Explanation	Under Plaster Version Model No	On Plaster Version Model No
With 1 gas w/o alarm	GZ71.58	GZ71.68
With 1 gas with alarm	GZ71.59	GZ71.69
With 2 gas w/o alarm	GZ71.60	GZ71.70
With 2 gas with alarm	GZ71.61	GZ71.71
With 3 gas w/o alarm	GZ71.62	GZ71.72
With 3 gas with alarm	GZ71.63	GZ71.73
With 4 gas w/o alarm	GZ71.64	GZ71.74
With 4 gas with alarm	GZ71.65	GZ71.75
With 5 gas w/o alarm	GZ71.66	GZ71.76
With 5 gas with alarm	GZ71.67	GZ71.77

Stainless Steel

Explanation	Under Plaster Version Model No	On Plaster Version Model No
With 1 gas with alarm	GZ71.83	GZ71.88
With 2 gas with alarm	GZ71.84	GZ71.89
With 3 gas with alarm	GZ71.85	GZ71.90
With 4 gas with alarm	GZ71.86	GZ71.91
With 5 gas with alarm	GZ71.87	GZ71.92

Area Gas Control Panels

Description

Inspital Area Gas Control Unit is manufactured to provide isolation of individual floors of medical gases in the hospital. Area Gas Control Unit includes all features required by the EN ISO 7396-1 and HTM O2-01 standards. Isolation may be required for installation, maintenance or in the case of an emergency

Classification

- Area Gas Control Unit is manufactured HTM O2-01, HTM 2022, EN ISO 7396-1 and BS EN 15908.

Services

- Oxygen
- Nitrous Oxide
- Medical Air 400 kPa
- Surgical Air 700 kPa
- Medical Vacuum

Features

- Controls 1 to 5 gases, including vacuum
- Lockable covers with emergency access lock system
- Window on the cover enables the user to monitor the analog manometers without opening the covers
- Under plaster and on plaster types are available

Alarm Unit

- Local Area Alarm

Pressure Switches

- Pressure switches can be fitted inside the box to enable local monitoring.

Area Gas Control Panels With Second Stage Regulator

- Second stage pressure reducing from 10 bar to 7 bar or 4 bar
- Lockable covers with emergency access lock system
- Stainless steel valve box
- Double or single regulators option
- Under plaster and on plaster types are available

Explanation	Under Plaster Version Model No	On Plaster Version Model No
With 1 gas	GZ71.83F	GZ71.88F
With 2 gas	GZ71.84F	GZ71.89F
With 3 gas	GZ71.85F	GZ71.90F
With 4 gas	GZ71.86F	GZ71.91F
With 5 gas	GZ71.87F	GZ71.92F



Digital Alarm Panels

Inspital Medical Gas Alarm panel monitor the medical gas source equipment and the operating pressures in the pipeline distribution system, as well as, the critical care areas of the facility to ensure that the medical gas and vacuum systems remain safe for patient use.



Inspital Digital Alarm Panel is designed and manufactured in compliance with HTM2022, HTM 02-01, C11, BS EN 60601-1-2 and BS EN ISO 7396-1.

Sensor-mounted alarm panel displays can be monitored on the computer and other panels without sensor by RS232 communication protocol.

Capacity	Analog Model No
Single Gas	GZ71.78
Double Gas	GZ71.79
Triple Gas	GZ71.80
Four Gas	GZ71.80F
Five Gas	GZ71.81



Central Alarm Panels

Designed to be used in central gas station manifold systems Audible and visual alarms in case of pressure problems The panel works with two high pressure switches and one positive pressure sensor to detect pressure changes Sensors and switches are not included

Model: GZ71.93

Medical Gas Plants

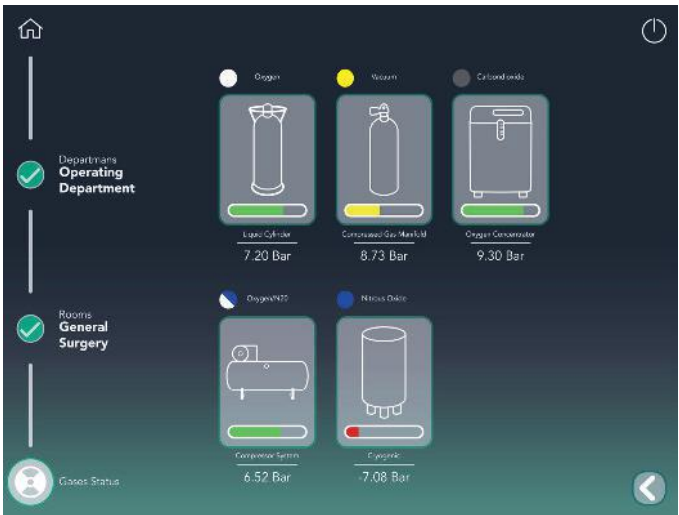
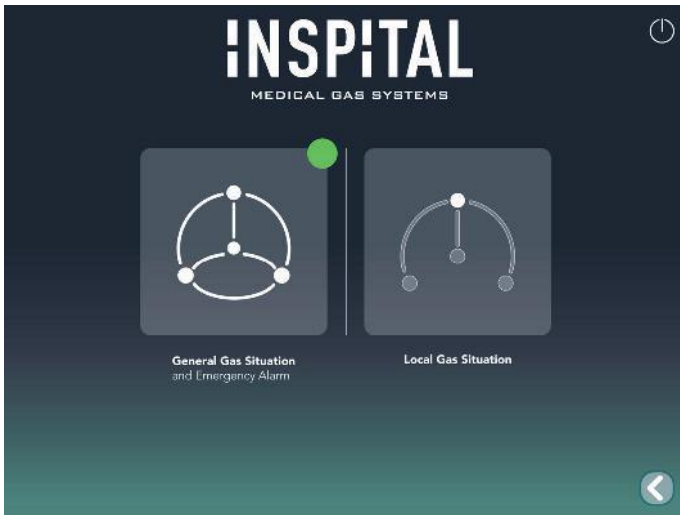

MEDICAL GAS ALARM MANAGEMENT SYSTEM

INSPITAL developed an automation system which allows users to monitor all running medical gas system of the hospital.

Monitoring system collects all data from the alarm panel of central vacuum system, medical air system, manifold system and area control panels. All those instant data can be displayed on specified touch monitor, any computer in related departments or by the technicians.

All stations or specified stations can be monitored instantly. System records all signals of operating and emergency alarms. Alarms are monitored both visually and audible indicators.

The Alarm Management System makes sure that technical and clinical personnel are kept informed about the status of the central gas supply at all times. It monitors the GMS in all areas and records all signals such as operating and emergency alarms.

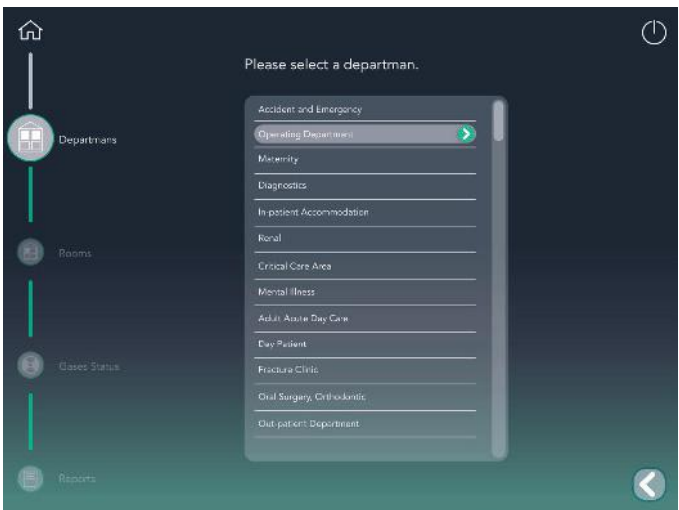

Medical Vacuum Station

Medical Vacuum is an essential requirement of the supply system for medical gases in hospitals. Inspital develops and manufactures fully automatic, stable and highly reliable vacuum stations which are used to aspirate fluids in the operating theatres, on ICU and on regular patient rooms.

Inspital Medical Vacuum Plants are designed and manufactured in compliance with HTM 02-01, HTM 2022, MDD 93/42/EEC EN ISO 7396-1 and C11 standards.

- Station is fully controlled by PLC system. This system enables equal aging of vacuum pumps which means a much longer operating life time
- Protected by bacterial filters
- Equipped with lubricated rotary vane vacuum pumps

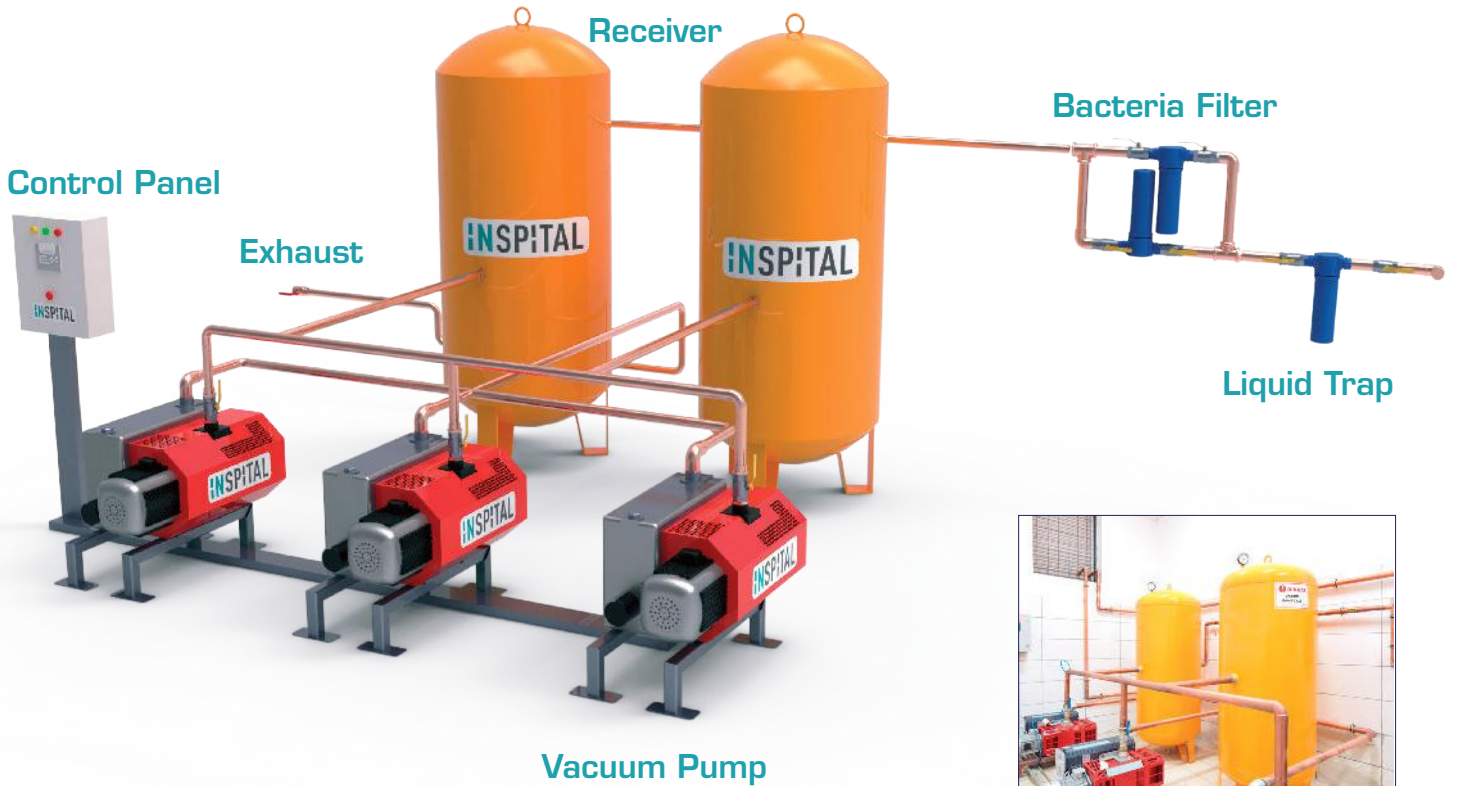

Vertical Type- Central Vacuum Station

- Designed to be used for central vacuum systems in operating theatres, ICUs, emergencies and laboratories of hospitals
- PLC controlled full automatic system
- Compact and modular design
- Medical type high efficiency bacteria filters
- Lubricated rotary vane vacuum pumps
- Sliding shelves enable easy access for maintenance



Model No	VK40.02	VK40.03	VK40.04	VK40.05	VK40.06	VK40.07
System Capacity (m ³ /h) (50 Hz)	47x2	47x3	100x2	100x3	200x2	200x3
Power (kW) (50 Hz)	1,10x2	1,10x3	2,20x2	2,20x3	4,00x2	4,00x2
Pump Qty	2	3	2	3	2	3
Tank Capacity	500	500	1000	1000	1500	1500
Bactery Filter Qty	1 pc	1 pc	1 pc	2 pc	2 pc	2 pc
Liquid Trap	1 pc	1 pc	1 pc	1 pc	1 pc	2 pc
Inlet hose dia.	1"	1"	1"1/4	1"1/4	2"	2"
Outlet hose dia.	1"	1"	1"1/2	1"1/2	2"	2"
Bed Qty	70	50-90	90-180	150-200	160-300	160-350

Tank Mounted – Central Vacuum Station

- Designed to stand alone assemblies with all components and filters mounted on a single horizontal vessel
- PLC controlled full automatic system
- Compact tank top design
- Suitable for low height medical gas plant rooms
- Specifically designed for ease of installation



Model No	VK40.08	VK40.09	VK40.10	VK40.11	VK40.12	VK40.13
System Capacity (m ³ /h (50Hz)	47x2	47x3	100x2	100x3	200x2	200x3
Power (kW) (50 Hz)	1,10x2	1,10x3	2,20x2	2,20x3	4,8x2	4,8x3
Pump Qty	2	3	2	3	2	3
Tank Capacity	500	500	1000	1000	1000	1000
Bactery Filter Qty	1 pc	1 pc	1 pc	2 pcs	2 pcs	2 pcs
Liquid Trap	1 pc	1 pc	1 pc	1 pc	1 pc	1 pc
PLC Qty	1	1	1	1	1	1
Inlet hose dia.	1"	1"	1"1/4	1"1/4	2"	2"
Outlet hose dia.	1"	1"	1"1/2	1"1/2	2"	2"
Bed Qty	70	50-90	90-180	150-200	160-300	160-350



PLC Control Panel

- Hospital PLC panels are fully automatic digital control units
- They are designed to control multiple vacuum pumps of central vacuum stations.
- It enables equal aging of pumps and longer lifetime for the vacuum stations

Pump Type	Capacity m ³ /h	Dimensions	Model No
Single	25 - 40	350x160x530 mm	VK40.23
Double	65 - 100	350x160x530 mm	VK40.24
Triple	150 - 200	350x160x530 mm	VK40.25



Bacteria Filter Set

- 100 m³/h flow capacity
- Integrated by-pass valves and discharge system
- Bacteria filtration of 30 micron

Pump Type	Model No
Single	VK40.26
Double	VK40.27



Liquid Trap

- High efficiency trap designed to drain liquids in vacuum pipeline
- 1.5 L capacity
- Inlet and outlet valves included

Model: VK40.28



Vacuum Tank

- Designed to use in central vacuum stations
- Different capacities for different stations
- Vertical or horizontal types available
- Made of highly durable steel material

Capacity (L)	Wall Thickness	Diameter	Length	Model No
500 L	5 mm	630 mm	1800 mm	VK40.29
750 L	5 mm	750 mm	1800 mm	VK40.30
1000 L	6 mm	850 mm	1920 mm	VK40.31
1500 L	6 mm	1100 mm	2200 mm	VK40.32



Vacuum Pumps

The lubricated rotary vane pumps VPS are designed to be used in a wide range of industrial and healthcare applications. They can run continuously from atmospheric pressure to ultimate vacuum.

- Specially designed for medical applications
- Stable and longlife pumps
- Lubricated rotary vane vacuum pumps
- Single stage vacuum pump
- High pumping speed even at low pressure
- Integrated oil mist filter on the exhaust
- Pumps can run continuously from atmospheric pressure to ultimate vacuum
- Silent and very robust pumps
- Options; Oil level switch, PT100 temperature sensor



Maintenance Kits

Usual maintenance (EC): 3 000 hours or 24 months **Model: VK40.40**

- Inspection / cleaning
- Oil change
- Oil filter replacement
- Oil separating cartridge(s) change
- Inlet valve overhaul
- Gas ballast filter change



Maintenance Kits

Preventive maintenance (MP): 12 000 hours **Model: VK40.41**

- Radial shaft seals change
- Sliding rings change
- Vanes replacement*
- End cover gaskets replacement
- Automatic drain + gaskets replacement
- Rubber feet replacement
- Coupling ring overhaul



- Options; Oil level switch, PT100 temperature sensor

Model No	Nominal Flow		Maximum Pressure				Motor Power		Oil Capacity	Weight
	m ³ .h ⁻¹		W/o Ballast		W/o Ballast		Kw			
	50 Hz	60 Hz	mbar	kPa	mbar	kPa	50 Hz	60 Hz		
VK40.16	30	35.3	0,5	0,05	1,5	0,15	0,75	0,9	1,5	39
VK40.17	47.7	56	0,5	0,05	1,5	0,15	1,1	1,32	1,5	52
VK40.18	64.3	72.2	0,5	0,05	1,5	0,15	1,5	1,8	4	75
VK40.19	96	115	0,5	0,05	1,5	0,15	2,2	2,70	4	85
VK40.20	132	156	0,1	0,01	1,2	0,12	3	3,6	5	154
VK40.21	198	240	0,1	0,01	1,2	0,12	4	4,8	5	140
VK40.22	293	354	0,1	0,01	1,2	0,12	5,5	6,6	5	162



VK40.14



VK40.15

Mini Vacuum Station

- Compact and independent ready-to-run vacuum plant
- Lubricated rotary vane vacuum pump
- Standard suction network inlet
- Bacteria filter with aspiration (optional)
- Liquid trap (optional)

Model No	VK40.14	VK40.15
Nominal Capacity (m ³ .h-1) 50 Hz	25	2x10
Power (kW) 50 Hz	0,75	2x0,35
Tank Capacity (L)	70	70
Noise Level dB (A)	60	60
Oil Capacity(L)	1,5	1,5
Weight (kg)	85	85



VK50.01
VK50.02



VK50.03
VK50.04

Anaesthetic Gas Scavenging System, Single and Double

Anaesthetic Gas Scavenging the Systems AGSS are designed to remove anesthetic gas mixture formed in the operating room. The AGSS shall comply with HTM O2-O1, Inspital Anaesthetic Gas Scavenging Systems are CE marked according to the Medical Device Directive 93/42/EEC. Anaesthetic Gas Scavenging Plant is classified as Class IIa Medical Devices.

Single and duplex blower versions are available Blowers are oil-free, air cooled side channel regenerative type and suitable for continuous operation.

Capacity	80 m ³ /h	130 m ³ /h	2x80 m ³ /h	2x130 m ³ /h
Power	0,76 kW	1,3 kW	2x0,76 kW	2x1,3 kW
Noise Level	63 dB (A)	66 dB (A)	63 dB (A)	66 dB (A)
Inlet dia	1"	1/22"	1" 1/2	2"
Outlet dia	Ø 44	Ø 60	Ø 44	Ø 60
Weight	45 kg	55 kg	120 kg	140 kg
Model No	VK50.01	VK50.02	VK50.03	VK50.04

Medical & Surgical Air Plant Systems

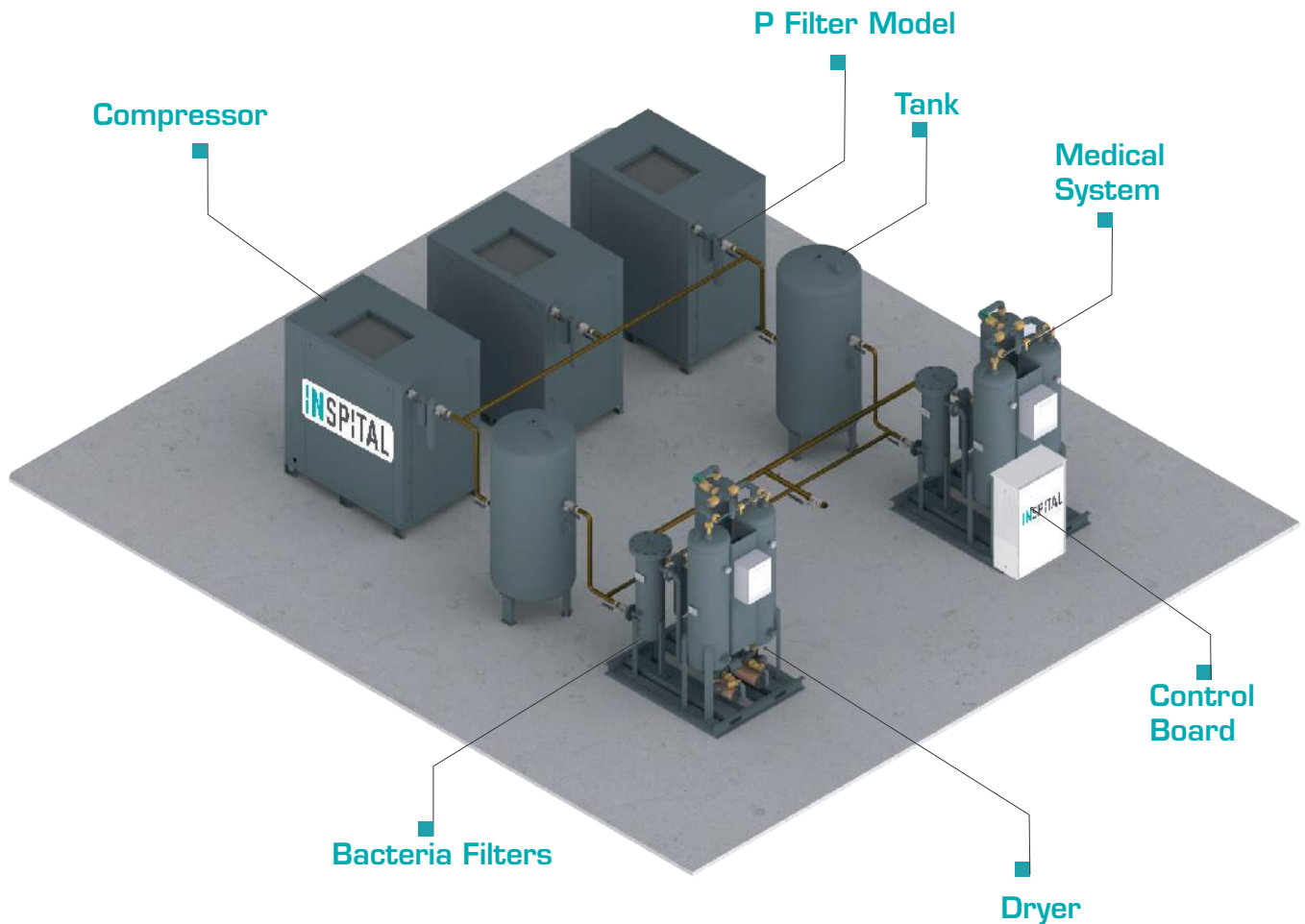

Medical Air

Medical air is mainly supplied via a medical gas pipeline system where the air is manufactured by compressors, dryers and filtration system.

In the hospitals medical air supply is a vital life support service, maintaining respiration of the critically ill patients during mechanical ventilation.

The main uses of medical air in the hospitals are:

- Driving ventilators and incubators, where it provides uncontaminated and controlled air flows helping to reduce high concentration of oxygen exposure,
- As a carrier gas for anaesthetic agents
- As a power source for driving surgical tools in the operating theatre

Inspital Medical Air Plants are designed and manufactured according to ISO 13485 Quality Management System and comply with MDD 93/42/EEC.



Medical Compressed Air

Medical Compressed air is a widely used gas in hospitals. Therefore, the requirements and quality standards are high. Medical compressed air is important for the ventilation of ICU patients the most important medical gas other than oxygen. International rules such as EN ISO 7396-1 and the European Pharmacopoeia guarantee the continuity of medical compressed air and ensure that quality control is carried out regularly. In addition, it defines the limit values that the medical air must have. With INSPITAL Medical Compressed Air Stations, we ensure that you obtain quality air according to EN ISO 7396-1 and European Pharmacopoeia.

Contamination	European Pharmacopoeia
O ₂	20.4% <x<21.4%
CO ₂	<500 ppm
CO	<5 ppm
SO ₂	<1 ppm
NO	<2 ppm
NO ₂	<2 ppm
H ₂ O	<67 ppm
Oil vapor	<0.1 mg/m ³

Medical Air System

Model No	Compressor Capacity	Compressor Pcs	Compressor Type	Tank Capacity	Medical Gas System	Operating Temperature	Bed Quantity
GZ80.20	78 m ³ /h	3	Screw Type	2x300 L	2	(+10) - (+50) C°	50-100
GZ80.21	115 m ³ /h	3	Screw Type	2x500 L	2	(+10) - (+50) C°	100-150
GZ80.22	168 m ³ /h	3	Screw Type	2x1000 L	2	(+10) - (+50) C°	150-200
GZ80.23	235 m ³ /h	3	Screw Type	2x1000 L	2	(+10) - (+50) C°	200-250
GZ80.24	276 m ³ /h	3	Screw Type	2x1500 L	2	(+10) - (+50) C°	250-300
GZ80.25	420 m ³ /h	3	Screw Type	2x2000 L	2	(+10) - (+50) C°	300-500



Technical Air System

Medical Air Plant is designed to provide a continuous supply of medical quality air. Medical air is mainly supplied via a medical gas pipeline system where the air is generated by compressors, dryers and filtration system.

Inspital Medical Air plant with rotary screw compressors can be used in wide capacity range. Compressor capacities varies from 2.2 kW to 37 kW. High quality screw blocks with perfect lubrication systems enable continuous operation, stability and reliability. At technical air solutions offers compressed air dryers with +3-5 C° dew point temperature.

Inspital can offer different capacities according to hospital consumption and bed capacity.

Model No	Compressor Capacity	Compressor Type	Dryer Capacity	Tank Capacity	Operating Temperature	Bed Quantity
GZ80.01	1x39 m ³ /h	Screw Type	1x50 m ³ /h	300 L	(+10) - (+50) C°	20-50
GZ80.02	2x39 m ³ /h	Screw Type	1x50 m ³ /h	300 L	(+10) - (+50) C°	20-50
GZ80.03	1x84 m ³ /h	Screw Type	1x87 m ³ /h	500 L	(+10) - (+50) C°	50-100
GZ80.04	2x84 m ³ /h	Screw Type	1x87 m ³ /h	500 L	(+10) - (+50) C°	50-100
GZ80.05	1x117 m ³ /h	Screw Type	1x130 m ³ /h	1000 L	(+10) - (+50) C°	100-150
GZ80.06	2x117 m ³ /h	Screw Type	2x130 m ³ /h	1000 L	(+10) - (+50) C°	100-150
GZ80.07	1x168 m ³ /h	Screw Type	1x170 m ³ /h	1500 L	(+10) - (+50) C°	150-200
GZ80.08	2x168 m ³ /h	Screw Type	2x170 m ³ /h	1500 L	(+10) - (+50) C°	150-200
GZ80.09	1x210 m ³ /h	Screw Type	1x283 m ³ /h	2X1000 L	(+10) - (+50) C°	200-250
GZ80.10	2x210 m ³ /h	Screw Type	2x283 m ³ /h	2X1000 L	(+10) - (+50) C°	200-250



Air Compressors

- Quiet and efficient axial fan directly connected to main motor
- Additional axial fan with temperature control
- Compact, small footprint, easy to service.
- Air tank made of CE certified P265GH pressurized container steel
- Compressor capacity 21 - 324 m³ / h
- Integrated PLC control until 2 compressor



Compressed Air Tank

- Made of ST-37 steel
- Operating pressure at 11 atm
- Manufactured and tested according to BS EN 286-1:1998+A2:2005 standards

Model No	GZ82.01	GZ82.02	GZ82.03	GZ82.04	GZ82.08
Capacity (L)	300	500	1000	1500	2000
Trunk (st-37)	(st-37)				
Inlet	1 1/2"				

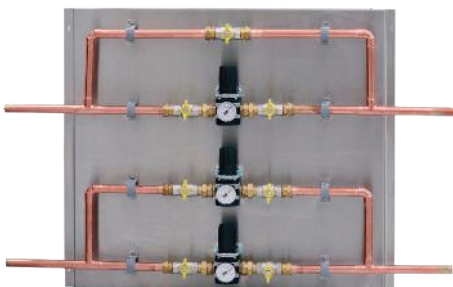

Compressed Air Regulator Group

- Air Regulator Group is the final regulation process of the air coming from the compressed air station.
- It is used to regulate the air pressure to required level (4 bar or 7 bar)

Model No	GZ82.05	GZ82.06
Capacity(m ³ /h)	100	200



Medical Air Plant with Oil-Free Compressors

Inspital allows medical air plants with high technology oil-free compressors.

These new generation compressors are reliable compact, silent and delivers of producing oil free compressed air. As compressors are designed for continuous operation, it is very reliable and efficient with low maintenance cost. Because of its compact design, installation is easy and air evacuation is smooth as it doesn't include any oil.

OIL FREE 

Model No	Compressor qty x capacity	Compressor Type	Dryer qty x capacity	Tank Capacity
GZ80.12	2x109 m ³ /h	Oil Free	1X100 m ³ /h	1500 L
GZ80.13	3x109 m ³ /h	Oil Free	2X100 m ³ /h	2x1000 L
GZ80.14	1x158 m ³ /h	Oil Free	1x190 m ³ /h	2x1000 L
GZ80.15	2x158 m ³ /h	Oil Free	1x190 m ³ /h	2x1000 L
GZ80.16	3x158 m ³ /h	Oil Free	2x190 m ³ /h	2x1500 L
GZ80.17	1x213 m ³ /h	Oil Free	1x210 m ³ /h	2x1000 L
GZ80.18	2X213 m ³ /h	Oil Free	1x210 m ³ /h	2x1500 L
GZ80.19	3X213 m ³ /h	Oil Free	2x210 m ³ /h	2x1500 L

Oil-free system provides 100% oil-free air and it has low noise level for hospital environment.

As there is no oil injected to the air, there is no need to invest for the purification of waste water. This is the best way to protect the environment.

Medical Gas Plants

Oxygen Production Systems

Inspital Oxygen Generators are new generation stations that allows on-site production of oxygen. This helps hospitals to supply oxygen from their own automated system independently. These systems are generally combined with cylinder systems for instant back up.

Inspital Oxygen Generators deliver oxygen in a purity up to 95% at flow rate from 3 to 50 m³/h. Station delivers constant purity rate independent from the consumption. Ideal system consists of air compressors, dryers, O₂ generator, active carbon tower, tanks and filters.

Features:

- Oxygen purity level and outlet pressure indicator
- Easy handling from Touch screen
- Automatic operation
- Reducing operation cost
- Return investment in less than 1 year
- Optional oxygen analyzer

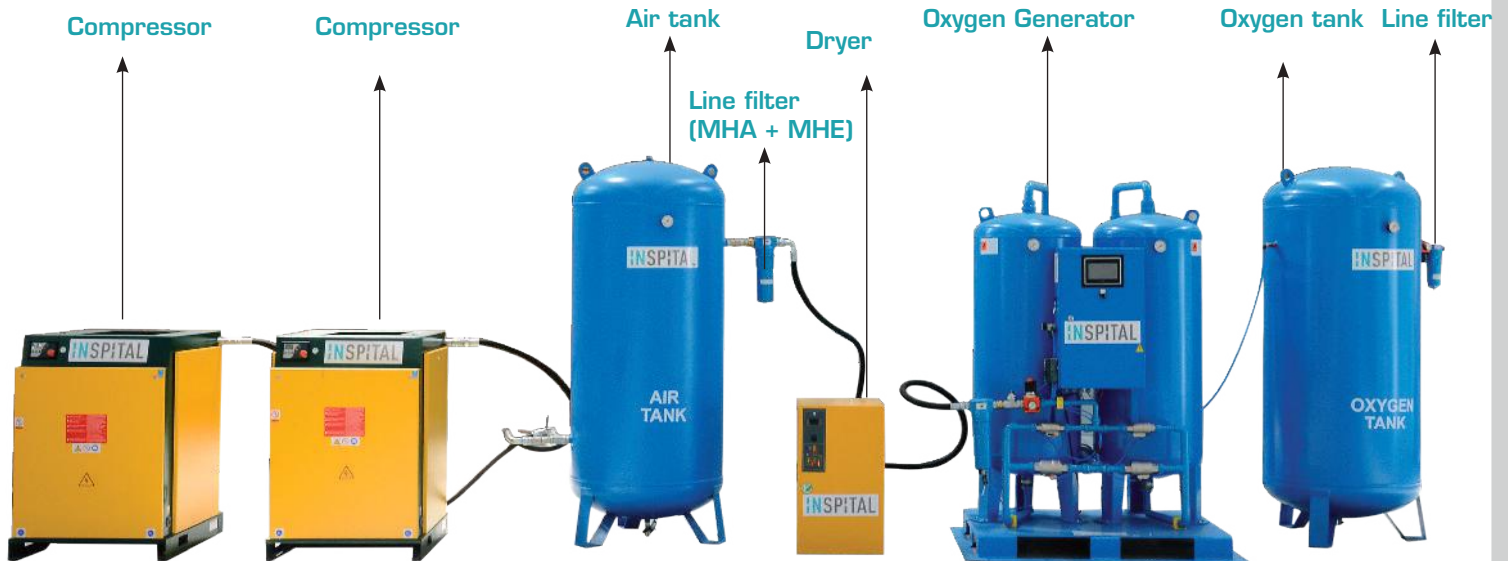

Model No	O ₂ Generator Capacity	Bed Number	Compressor Capacity (m ³ /h)	Compressor Type	Air Tank Capacity	Tank Capacity	Dreyer Capacity
GZ81.01	3 m ³ /h	50-100	7,5 kw/(0,92 m ³ /h)	Screw Type	500 L	500 L	CAD 30
GZ81.02	6 m ³ /h		11 kw/(1,40 m ³ /h)	Screw Type	500 L	500 L	CAD 52
GZ81.03	9 m ³ /h		22 kw/(3,2 m ³ /h)	Screw Type	1000 L	1000 L	CAD 61
GZ81.04	12 m ³ /h	100-150	22 kw/(3,2 m ³ /h)	Screw Type	1000 L	1000 L	CAD 61
GZ81.05	15 m ³ /h		30 kw/(4,4 m ³ /h)	Screw Type	1000 L	1000 L	CAD 110
GZ81.06	18 m ³ /h		30 kw/(4,4 m ³ /h)	Screw Type	1000 L	1000 L	CAD 110
GZ81.07	20 m ³ /h		30 kw/(4,4 m ³ /h)	Screw Type	1000 L	1000 L	CAD 110
GZ81.08	25 m ³ /h	150-200	30 kw/(4,4 m ³ /h)	Screw Type	1000 L	1000 L	CAD 110
GZ81.09	30 m ³ /h		45 kw/(6,2 m ³ /h)	Screw Type	1000 L	1000 L	CAD 170
GZ81.10	40 m ³ /h		55 kw/(9,2 m ³ /h)	Screw Type	2000 L	1500 L	CAD 200
GZ81.11	50 m ³ /h	200-250	75 kw/(10,6 m ³ /h)	Screw Type	2000 L	1500 L	CAD 250

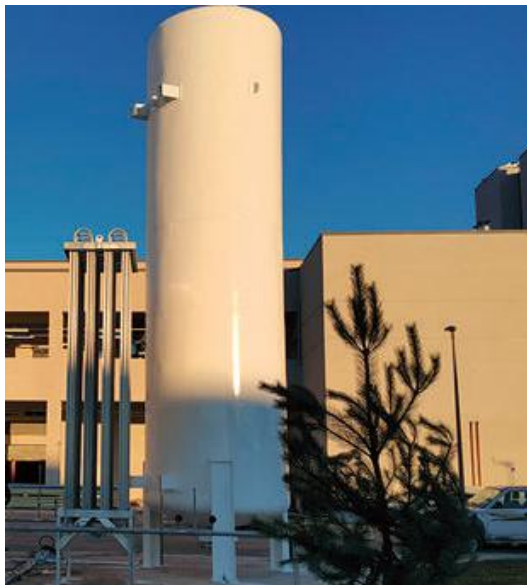

Cryogenic Oxygen Stations

Main components of the Cryogenic Oxygen Stations are liquid oxygen (LOX) storage tanks and evaporation systems.

Classification

Hospital LOX tanks are specially designed and Manufactured according to 2014/68/EU Pressure Equipment Directive (PED) EN 13445 – Annex C for long term storage of cryogenic liquified gases under pressure.

DESIGN CODE	EN 13458 - PED 97/23/EC
MAX. ALLOWABLE WORKING PRESSURE	19 bar
DESIGN TEMPERATURE	-196°C
INNER VESSEL MATERIAL	Stainless Steel (According to EN 10028-7)
OUTER VESSEL MATERIAL	Carbon Steel (According to EN 10025/EN 10028-3)
INSULATION	Perlite & Vacuum

Features:

- Optional long-distance control with telemetry
- Standard manual or optional digital level indicator
- TUV Austria approved and CE marked
- Included VIE control panel

Air Gas Standard Storage Tanks Dimensions

19 Bar Cryogenic lin/Lox/Lar Storage Tanks

Model no	Gros Capacity	Net Capacity (%95 Filling)	Daily Evap. Rate (O2)	ØD	B	L	W	H	Empty Weight
	liters	liters	%/day	mm	mm	mm	mm	mm	kg
GZ90.05	6200	5890	0.30	1830	5120	5910	2050	2120	3750
GZ90.10	10450	9930	0.29	2400	4640	5340	2400	2690	5300
GZ90.15	14850	14110	0.28	2400	6130	6830	2400	2690	6950
GZ90.25	24750	23510	0.24	2400	9925	10625	2400	2690	10800
GZ90.30	31300	29735	0.23	2680	9600	10300	2680	3020	11750
GZ90.50	50000	47500	0.19	3050	11300	3050	11300	12000	20500

Ambient Air Vaporizer

Ambient air vaporisers requires no external source of energy; and enables vaporization through exchange of heat with the surrounding air. The liquefied gas is vaporized, and warmed to almost the surrounding temperature, and finally led to the users in its gaseous state

The vaporisers are for use with liquid:

- Oxygen
- Nitrogen
- Argon
- Carbon Dioxide
- Nitrous Oxide
- LNG

Design Specifications

INSPITAL offers a full range of ambient air vaporizers in different versions and for different applications. Our following properties:

- Designed and manufactured according to PED 97/23/EC
- Has CE marking
- Max allowable working pressure 40 bar
- Cleaned for oxygen service
- Seismic requirements acc. to uniform building code-zone 4
- Low pressure drop
- Efficient fin tube desing
- Optimised external and internal surfaces for optimum convection

Vaporiser options

- Ambient air vopariser options are
- Fin tube vaporisers
- Fan assisted vaporiser

Fin tube vaporisers rely on natural convection while fan assisted models are equipped with an models are equipped with an enhance air flow and increase efficiency.



Model no	Exterior Surface (M2)	Capacity for LOX (Nm ³ /h)
GZ90.05	29	93
GZ90.10	59	186
GZ90.15	117	372
GZ90.25	205	650
GZ90.30	292	929
GZ90.50	400	1274

The evaporator selection is made according to consumption of hospital.

Evaporator needs to change between reserve at every 8 hours.

The evaporator capacities to be selected according to the external surface will vary according to the outdoor temperature, working time and fluid type.



Copper Tubes

Pipeline solutions for medical installations

- Medical copper tubes are degreased and marked according to EN 13348 System in accordance with requirement of the medical gas market.
- Straight length copper tube is available in 4m lengths and individually red capped.
- We have stocks of medical copper tubes available for immediate dispatch.
- Special wooden cases packaging is suitable for exporting delivery.

Specific Benefits Include:

- Specifically designed for copper medical gas and vacuum systems. Superseding earlier 'hybridised' copper tube standards such as BS EN1057 & BS 2871 Part 1 quoted in HTM 2022 & NHS engineering spec.
- Tighter limits on cleanliness determination.
- Sizes 8 - 108mm copper tubes are stamped with

Copper Pipe Label

Model No	Explanation
MB30.01	Oxygen 250 pcs
MB30.02	Vacuum 250 pcs
MB30.03	Air 250 pcs
MB30.04	Nitrogen 250 pcs
MB30.05	Agss 250 pcs

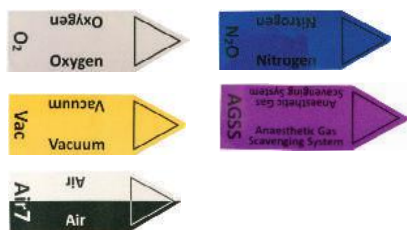





Model No	Explanation	Thickness	Working Pressure	Length
MB10.01	8 mm	1,0 mm	84 bar	4 m
MB10.02	10 mm	0,6 mm	84 bar	4 m
MB10.03	10 mm	1,0 mm	84 bar	4 m
MB10.04	12 mm	0,6 mm	77 bar	4 m
MB10.05	12 mm	1,0 mm	77 bar	4 m
MB10.06	15 mm	0,7 mm	63 bar	4 m
MB10.07	15 mm	1,0 mm	63 bar	4 m
MB10.08	22 mm	1,0 mm	58 bar	4 m
MB10.09	28 mm	1,0 mm	51 bar	4 m
MB10.10	28 mm	1,5 mm	51 bar	4 m
MB10.11	35 mm	1,0 mm	40 bar	4 m
MB10.12	35 mm	1,5 mm	40 bar	4 m
MB10.13	42 mm	1,0 mm	42 bar	4 m
MB10.14	42 mm	1,5 mm	42 bar	4 m
MB10.15	54 mm	1,5 mm	27 bar	4 m
MB10.16	54 mm	2,0 mm	27 bar	4 m
MB10.17	76 mm	1,5 mm	29 bar	4 m
MB10.18	76 mm	2,0 mm	29 bar	4 m
MB10.19	108 mm	2,0 mm	16 bar	4 m
MB10.20	108 mm	2,5 mm	16 bar	4 m

Copper Tubes And Accessories

Fittings & Accessories

- Inspital's end feed fittings, manufactured to BS EN 1254-1; 1998 are seamless, one piece fittings, which makes them stronger and easier to use.
- Biostatic composition of the copper material inhibits bacterial growth on its surface
- End connections: Copper x Copper
- Lightweight, strong and corrosion resistant
- Unaffected by sunlight, has no special storage requirements and cannot produce toxic fumes in a fire.
- All fittings supplied contain less than 100mg/m² (0.01mg cm²) of hydrocarbons on the degreased surface.



				
	Elbow 90	Equal T	Coupling	Reducer
Diameter	Model No	Model No	Model No	Model No
10 mm	FT50.01	FT50.09	FT50.28	FT50.17 / 12x10 mm
12 mm	FT50.02	FT50.10	FT50.29	FT50.18 / 15x12 mm
15 mm	FT50.03	FT50.11	FT50.30	FT50.19 / 22x12 mm
22 mm	FT50.04	FT50.12	FT50.31	FT50.20 / 15x22 mm
28 mm	FT50.05	FT50.13	FT50.32	FT50.21 / 15x28 mm
35 mm	FT50.06	FT50.14	FT50.33	FT50.22 / 22x28 mm
42 mm	FT50.07	FT50.15	FT50.34	FT50.23 / 22x35 mm
54 mm	FT50.08	FT50.16	FT50.35	FT50.24 / 54x22 mm
				FT50.25 / 54x28 mm
				FT50.26 / 54x35 mm
				FT50.27 / 76x54 mm

Copper Pipe Clips

- Inspital designed clips used as copper tube supports on ceilings and walls.
- Rail type, directly connectable and color coded
- Single and jointed usage
- Compatible with gas standard
- Halogen free, non-flammable material



Explanation	Blue	White	Gray	Yellow
Hook 10 - 12 mm	FT50.39	FT50.46	FT50.53	FT50.60
Hook 15 mm	FT50.40	FT50.47	FT50.54	FT50.61
Hook 22 mm	FT50.41	FT50.48	FT50.55	FT50.62
Hook 28 mm	FT50.42	FT50.49	FT50.56	FT50.63
Hook 35 mm	FT50.43	FT50.50	FT50.57	FT50.64
Hook 42 mm	FT50.44	FT50.51	FT50.58	FT50.65
Hook 54 mm	FT50.45	FT50.52	FT50.59	FT50.66

Model No	Explanation
FT50.36	Hook Rail
FT50.37	Stoper
FT50.38	Distance

Medical Gas Outlets and Accessories



Medical Gas Outlets

Outlet Dia : 45 mm
Copper Pipe Dia : 10 mm
Production Standard : BS 5682/EN ISO 9170-1
Color Codes : Oxygen – White
 Vacuum – Yellow
 Nitrous Oxide – Blue
 Compressed Air – Black & White

	Oxygen	Vacuum	Air 4	Air 7	N ₂ O	CO ₂
DIN	PR80.01	PR80.02	PR80.03	PR80.04	PR80.05	PR82.01
BS	PR80.06	PR80.07	PR80.08	PR80.09	PR80.10	

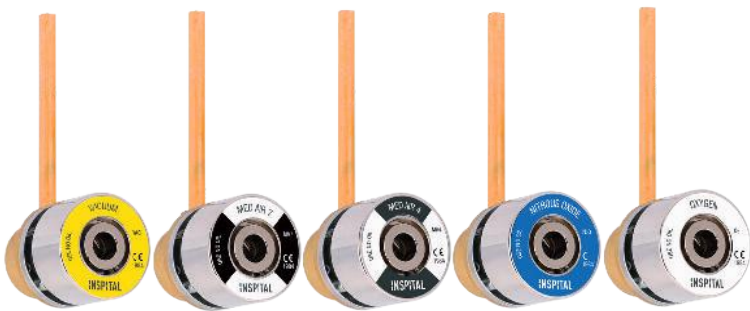

Medical Gas Outlets



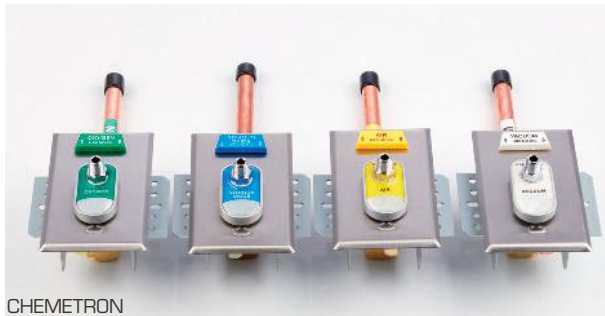

Outlet Dia : 49 mm
Copper Pipe Dia : 10 mm
Production Standard : BS 5682/EN ISO 9170-1
Color Codes : Oxygen – White
 Vacuum – Yellow
 Nitrous Oxide – Blue
 Compressed Air – Black & White

	Oxygen	Vacuum	Air 4	Air 7	N ₂ O	CO ₂
DIN-90°	PR80.11	PR80.12	PR80.13	PR80.14	PR80.15	PR82.02
BS-90°	PR80.16	PR80.17	PR80.18	PR80.19	PR80.20	
AFNOR-90°	PR80.21	PR80.22	PR80.23	PR80.24	PR80.25	
DIN-45°	PR82.11	PR82.12	PR82.13	PR82.14	PR82.15	PR82.03
BS-45°	PR82.16	PR82.17	PR82.18	PR82.19	PR82.20	
AFNOR-45°	PR82.21	PR82.22	PR82.23	PR82.24	PR82.25	



Medical Gas Outlets

- Outlet Size** : 62 X 96 mm
- Copper Pipe Dia** : 10 mm
- Production Standard** : BS 5682/EN ISO 9170-1
- Color Codes** : Oxygen – White
 Vacuum – Yellow
 Nitrous Oxide – Blue
 Compressed Air – Black & White

				
	Oxygen	Vacuum	Air	N ₂ O
DISS	PR80.32	PR80.33	PR80.34	PR80.35
CHEMETRON	PR80.36	PR80.37	PR80.38	PR80.39
OHMEDA	PR80.40	PR80.41	PR80.42	PR80.43



AGSS Terminal Units

Inspital AGSS terminal units are designed according to safety and performance requirements of EN ISO 9170-2 standard

Technical specifications

- Can be used as under plaster, on plaster or pendant outlet
- Special port to enable safe connection
- Venturi Type Outlet option
- Made of S/S frame and chrome plated brass material

								
Probe Type	BS	BS Probe	DIN (Venturi Type)			DIN Probe	Air Motor	Air Motor Probe
Model No	PR80.26	PR80.27	PR80.28	PR80.29	PR80.30	PR80.31	PR81.32	PR81.33

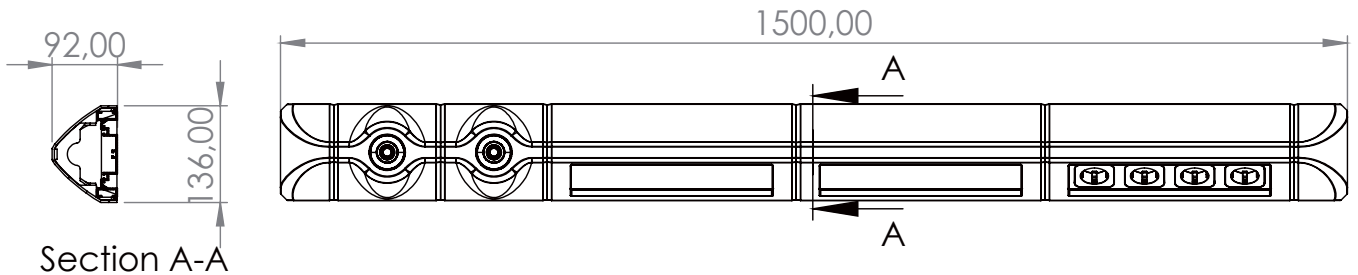
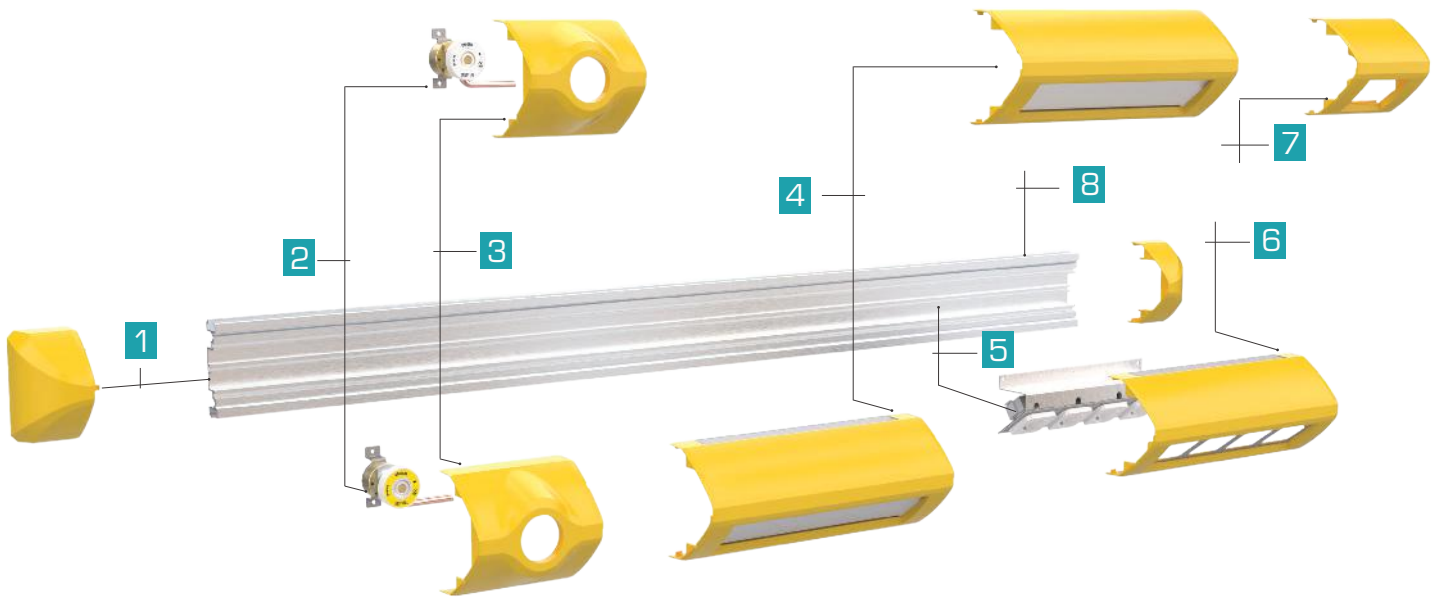





Section A-A

Modular Bed Head Units

- 1- Side Hatch
- 2- Outlets Set
- 3- Med.Gas Outlet Module (Single Port)
- 4- Led Lighting Module
- 5- Electrical Outlets Set
- 6- Electrical Power Module (3/4/5 Sockets)
- 7- Electrical Power Module (Single Sockets)
- 8- Aluminium Shape

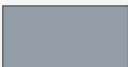
Colour Options

	White	RAL9003
	Yellow	RAL1018
	Light Grey	RAL7040
	Anthracite	RAL7015

Patient Bed Head Units

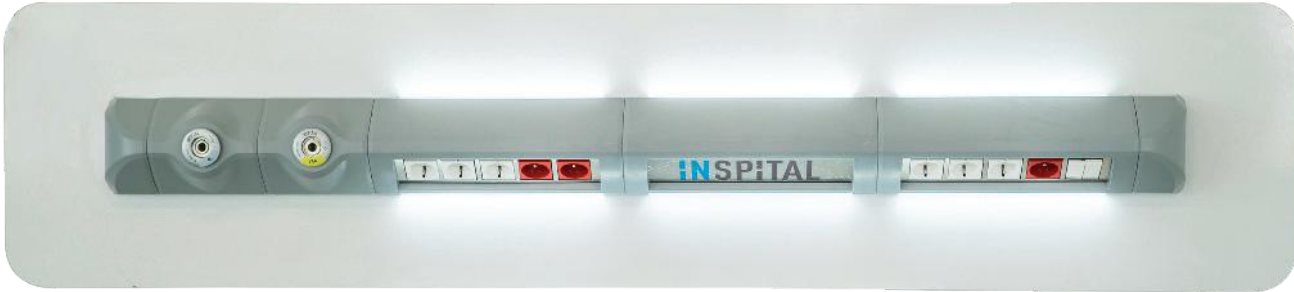

Modular Bed Head Units

New generation Inspital bed head units are designed for new generation hospitals which requires functional, extendable and modular bed head units.

Manufactured according to EN 11197 and fully meets all the standards of this regulation.

Innovative design of modular bed head units offer:

- Modular structure
- Configurable unit according to customer's needs both during the order and after the installation
- Aluminum main frame
- ABS cover (optional anti-bacterial version)
- Wide range of color options
- LED light for reading and ambient lighting (optional fluorescent light)
- Electrical sockets available for different country standards
- Name plate option on lamp module



Explanation	Length	Model No
Single bed	1500-1800 mm	GB22.30
Double bed	3000-3600 mm	GB22.40



Patient Bed Head Unit with Three Channels and Double Lamps,

Inspital Patient Bed Head Units are designed to provide integrated solutions of medical gas outlets, nurse call systems and electrical outlets in patient areas. Our Bedhead Units are designed and manufactured in compliance with EN 11197 standard. Each unit is custom manufactured to your specific requirements.



Standard Accessories

- Electrical socket :3 pcs 220 V (BS and DIN)
- Reading lamp :2 pcs
- Power button :1 pc

Explanation	Length	Model No
Single bed	1500-1800 mm	G822.35
Double bed	3000-3600 mm	G822.45

Patient Bed Head Unit with Three Channels and Double Lamps,

Inspital Patient Bed Head Units are designed to provide integrated solutions of medical gas outlets, nurse call systems and electrical outlets in patient areas. Our Bedhead Units are designed and manufactured in compliance with EN 11197 standard. Each unit is custom manufactured to your specific requirements.



Standard Accessories

- Electrical socket :3 pcs 220 V (BS and DIN)
- Reading lamp :2 pcs
- Power button :1 pc

Explanation	Length	Model No
Single bed	1500-1800 mm	GB22.10
Double bed	3000-3600 mm	GB22.20

ICU Type Patient Bed Head Unit with Double Channel and Double Rail

Inspital Patient Bed Head Units are designed to provide integrated solutions of medical gas outlets, nurse call systems and electrical outlets in patient areas, especially in ICU's. Our Bedhead Units are designed and manufactured in compliance with EN 11197 standard.

Standard Accessories

- Electrical socket 6 pcs (BS and DIN)
- Earth node 4 pcs



GB22.01
GB22.02



GB22.31
GB22.32

Explanation Wall Type	Length	Model No
Single bed	1500-1800 mm	GB22.01
Double bed	3000-3600 mm	GB22.02
Single bed	1500-1800 mm	GB22.31
Double bed	3000-3600 mm	GB22.32

Ceiling support profiles	Explanation	Model No
	For single BHU	GB52.01
For double BHU	GB52.02	

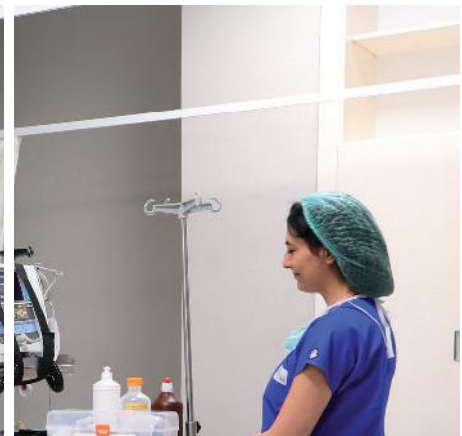



Model: FX40.25
Double Joint, Motorised
Pendant

Model: FX40.20
Single Joint, Motorised
Pendant

Model: FX40.15
Double Joint Pendant
with Double Shelf

Model: FX40.10
Single Joint Pendant
with Double Shelf

Pendants

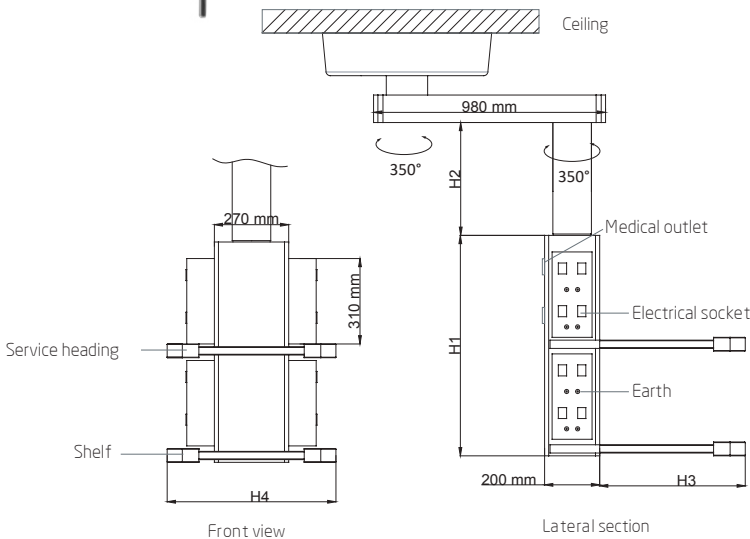

Pendant Systems

Hospital single joint pendants are designed to provide single point service for medical gas, electricity and equipment positioning nearby the patient. Mobility, flexibility and heavy duty design gives a strong support in operating theatres. Every pendant is custom design by our experienced sales support team.

Features

- High payload capacities until 1.000 kg
- Color coded brake buttons and joints
- Optional electromagnetic and pneumatic brake system
- Optional bluetooth sound system
- Visual indicators for movements

Standard Accessories

- Power Outlet: 8 Number UK, USA, Europe
- Grounding Note: 8 Pcs
- Rail Shelf: 1 Pc
- IV Pole 2 Pcs

Optional Accessories

- Shelves
- IV Pole
- Drawer
- Data socket (RJ45)
- Pressure gauge for Medical Gases
- Medical gas outlets (BS, DIN, NF)

H1 dimensions	H2 dimensions	H3, H4 dimensions
600 mm	300 mm	500x400
800 mm	500 mm	
1000 mm	700 mm	
1200 mm	900 mm	
	1100 mm	



Model: FX40.05
Pendant with Monitor Shelf

Model: FX40.20D Heavy
Duty Double Joint
Pendant

Model: FX40.15M
Heavy Duty Motorised
Pendant

Model: FX40.10S Heavy
Duty Single Joint
Pendant



**Infusion Pump Hanger,
Double, Rail Type**

Explanation	Model No
Double	SR10.22



Serum Hanger

Explanation	Model No
Clamp	SR10.32



Infusion Pump With Connector

Explanation	Model No
Connector Inclusive	SR10.33



**Basket, Stainless Steel,
Rail Type**

Explanation	Model No
220x220x240 mm	FX41.01
220x400x240 mm	FX41.02



Monitor Tray, Rail Type

Explanation	Model No
Rail Type	FX41.03



Monitor Tray, Wall Type

Explanation	Model No
400 mm Height Adjustment	FX41.04



Shelf for Pendants

Explanation	Model No
500 x 400 mm	FX41.05



**Shelf with Drawer for
Pendants**

Explanation	Model No
500 x 400 mm	FX41.06



**Examination Lamp LED,
Rail Type**

Explanation	Model No
Rail Type (LED)	LP10.05



Bridge Type ICU Pendant

Inspital bridge type pendants are used to provide medical gas outlets, electrical outlet and convenient device positioning around the patient in ICU, recovery and similar departments

Standard Accessories:

Electrical Socket	: 6 pcs EUR/UK/USA
Equipment shelf	: 3 pcs
IV pole	: 1 pc
Drawer	: 2 pcs

Optional Accessories:

Medical gas outlets (BS/DIN/NF), data outlet (RJ45), manometer for medical gases

Technical Specifications

Material	: Main frame: aluminum; Shelves: 1mm steel
Movements	: Shelves move horizontally in the rail and rotate manually
Loading capacity	: 50 kg
Color	: RAL colors are available
Power Input	: 220V AC - 50 Hz
Dimensions	: (WxLxH)350x2200 x1300mm

Model: FX40.50



Medical Gas Outlets and Accessories



Outlet Boxes, On Plaster/ Under Plaster

- Made of 304 quality S/S material
- Suitable to install on plaster / under plaster
- Several length and outlet standard alternatives

On Plaster Model	Under Plaster Model	Length	Outlet Qty
PR81.01	PR81.07	310 mm	2
PR81.02	PR81.08	460 mm	3
PR81.03	PR81.09	610 mm	4
PR81.04	PR81.10	760 mm	5
PR81.05	PR81.11	910 mm	6
PR81.06	PR81.12	1110 mm	7

- Without outlets



Plastic Outlet Boxes, Under Plaster

- Made of durable plastic material
- Suitable for under plaster installation
- Several length and outlet standard alternatives

Explanation	Length	Outlet Qty	Model No
Under Plaster	100 mm	1	PR81.17
Under Plaster	250 mm	2	PR81.18
Under Plaster	400 mm	3	PR81.19
On Plaster	100 mm	1	PR81.20

- Without outlets



Medical Gas Hoses

- Special hoses for medical gases
- Made of thermoplastic and rubber material
- Color coding according to EN 739 standard
- Suitable up to 20 bar pressure
- Inner dia: 6,7 mm Outer dia: 12 mm







Hose Type	Model No
O2, 250 cm	PR81.13
N2O, 250 cm	PR81.14
AIR, 250 cm	PR81.15
VAC, 250 cm	PR81.16



Probes

Inspital probes are produced according to international standards by using a special labelling for gases. They are used to supply necessary gases from terminal units to the patient or medical equipments via hose connections or by direct connection to the equipment. Inspital Probes are manufactured in compliance with BS 5682:1992, DIN 13260, AFNOR NF S 90-116.

- Manufactured according to BS, DIN & AFNOR standard
- Special connections for O₂, N₂O, AIR 4 and AIR 7
- Special labeling for each gas type
- Safe hose connection
- Made of chrome plated brass material or Stainless Steel

							
		BS	DIN	AFNOR	DISS	CHEMETRON	OHMEDA
Oxygen	Stainless Steel	JK90.50	JK90.51	JK90.52	JK90.53	JK90.54	JK90.55
	Brass	JK90.56	JK90.57	JK90.58	-	-	-
Vacuum	Stainless Steel	JK90.60	JK90.61	JK90.62	JK90.63	JK90.64	JK90.65
	Brass	JK90.66	JK90.67	JK90.68	-	-	-
Air 4	Stainless Steel	JK90.70	JK90.71	JK90.72	JK90.73	JK90.74	JK90.75
	Brass	JK90.76	JK90.77	JK90.78	-	-	-
Air 7	Stainless Steel	JK90.80	JK90.81	JK90.82			
	Brass	JK90.86	JK90.87	JK90.88	-	-	-
N ₂ O	Stainless Steel	JK90.90	JK90.91	JK90.92	JK90.93	JK90.94	JK90.95
	Brass	JK90.96	JK90.97	JK90.98	-	-	-
CO ₂	Stainless Steel	JK91.10	JK91.11	JK91.12			
	Brass	JK91.16	JK91.17	JK91.18	-	-	-



Flowmeters

Inspital offers different models of flowmeters according to their gas flow scale, connection types and humidity jars that can be used with oxygen.

Flowmeters can be either connected to medical gas outlets directly or attached on rail system and connected to the outlets by flexible hoses.

Size (LxWxH)	:80 x 48 x 145 mm
Inlet	:Whitworth GAS 1/8"
Pressure	:4.2 Kgs/cm ² – 60 psi – 414 kPa
Flow Rate	:0 - 15 L/min
Humidifier capacity	:200 ml

Flowmeters L/min	Without Adaptor	BS 5682	DIN 13260	NF 90 116	DISS	CHEMETRON	OHMEDA
Oxygen							
Wall type	FM20.11	FM20.21	FM20.31	FM20.41	FM20.51	FM20.61	FM20.71
Rail type	FM20.12	FM20.22	FM20.32	FM20.42	FM20.52	FM20.62	FM20.72
Dual wall type	FM20.13	FM20.23	FM20.33	FM20.43	FM20.53	FM20.63	FM20.73
Dual rail type	FM20.14	FM20.24	FM20.34	FM20.44	FM20.54	FM20.64	FM20.74
Air							
Wall type	FM20.15	FM20.25	FM20.35	FM20.45	FM20.55	FM20.65	FM20.75
Rail type	FM20.16	FM20.26	FM20.36	FM20.46	FM20.56	FM20.66	FM20.76
Dual wall type	FM20.17	FM20.27	FM20.37	FM20.47	FM20.57	FM20.67	FM20.77
Dual rail type	FM20.18	FM20.28	FM20.38	FM20.48	FM20.58	FM20.68	FM20.78



Calibrated Flowmeters















Calibrated Mobile Flowmeters

Variable Area Flowmeters

- Nipple with double thread, interchangeable by the end user
- I/O switch. Quick push switch button
- Graduated scale reading, measurement tube with "lens effect"
- Adjusting knob. Big size, with Push&Lock position set system and Soft Grip inserts for easy handling

Size (LxWxH): :61x107x175 mm
 Gas supply pressure : :280÷600 kPa
 Gas options: :O₂ , Air
 End of scale values : : 15 L/min.
 Flow calibration data: :1013 mbar 23 °C

Variable Area Flowmeters L/min	Without Adaptor						
		BS 5682	DIN 13260	NF 90 116	DISS	CHEMETRON	OHMEDA
Wall type	FM21.11	FM21.21	FM21.31	FM21.41	FM21.51	FM21.61	FM21.71
Rail type	FM21.12	FM21.22	FM21.32	FM21.42	FM21.52	FM21.62	FM21.72
Dual wall type	FM21.13	FM21.23	FM21.33	FM21.43	FM21.53	FM21.63	FM21.73
Dual rail type	FM21.14	FM21.24	FM21.34	FM21.44	FM21.54	FM21.64	FM21.74

Calibrated Orifice Flowmeters L/min	Without Adaptor						
		BS 5682	DIN 13260	NF 90 116	DISS	CHEMETRON	OHMEDA
Wall type	FM21.15	FM21.25	FM21.35	FM21.45	FM21.55	FM21.65	FM21.75
Rail type	FM21.16	FM21.26	FM21.36	FM21.46	FM21.56	FM21.66	FM21.76
Dual wall type	FM21.17	FM21.27	FM21.37	FM21.47	FM21.57	FM21.67	FM21.77
Dual rail type	FM21.18	FM21.28	FM21.38	FM21.48	FM21.58	FM21.68	FM21.78



150 ml

300 ml

120 ml

355 ml

	150 ml	300 ml	120 ml	355 ml
Model No	FM21.80	FM21.84	FM21.82	FM21.83

Flowmeter Humidifier Bottle

- Designed to humidify oxygen before patient's respiration
- Made of polycarbonate and scaled
- Sterilizable up to 121 °C For 15 min
- 120, 150, 300, 355 ml capacity options
- Connection to Flowmeter : Moving pipe union
- Lid material : Plastic
- Included relief valve



Oxygen Mask and Hose

- Oxygen concentration delivered is 40%-60% depending on the patient's breathing. The masks are connected directly to a compressed air or oxygen supply. The products are intended for single use only.
- 2.1m oxygen tubing
- Mask, oxygen tubing material: Polyvinyl chlorid







Model No	Explanation
AT20.60	Adult
AT20.61	Pediatric
AT20.62	Hose

Respiration Equipment



Probe with Manometer







- Chrome plated brass trunk
- Flow adjustment knob
- Pressure or vacuum gauge
- Gas specific connection port
- Suitable outlet for hose connection

Gas Type	Without Adaptor						
Oxygen	FG50.10	FG50.11	FG50.12	FG50.13	FG50.14	FG50.15	FG50.16
Nitrous Oxide	FG50.20	FG50.21	FG50.22	FG50.23	FG50.24	FG50.25	FG50.26
Vacuum	FG50.30	FG50.31	FG50.32	FG50.33	FG50.34	FG50.35	FG50.36
Medical Air 4	FG50.40	FG50.41	FG50.42	FG50.43	FG50.44	FG50.45	FG50.46
Medical Air 7	FG50.50	FG50.51	FG50.52	FG50.53	FG50.54	FG50.55	FG50.56



Vacuum Regulators







- On / Off lever for instant vacuum cut
- Autoclavable safety jar to avoid fluid leakage into central vacuum line
- Chrome plated brass trunk
- Easy to read vacuum gauge
- Flow adjustment knob

Gas Type	Without Adaptor						
Vacuum	FG51.01	FG51.02	FG51.03	FG51.04	FG51.05	FG51.06	FG51.07



Vacuum Regulator







- The regulator is made of a strong techno-polymer body, with a quick I/O switch-button, a suction adjustment knob and a control vacuum gauge with three possible end-of-scale choices: -250 mbar pediatric and -1000 mbar.
- De-pressure Safety valve included
- Autoclavable safety jar to avoid fluid leakage into central vacuum line
- Max. suction flow - 1000 : 115 L/min at -950 mb
- Max. suction flow - 250 : 50 L/min at -220mbar
- Vacuum gauge : 0 + -1000 mbar
- I/O switch : Quick push switch button

Gas Type	Without Adaptor						
Vacuum - 1000 mbar	FG52.10	FG52.11	FG52.12	FG52.13	FG52.14	FG52.16	FG52.15
Vacuum - 250 mbar	FG52.20	FG52.21	FG52.22	FG52.23	FG52.24	FG52.26	FG52.25



Venturi Type Vacuum Regulator

- Designed to provide vacuum by using compressed air or oxygen source
- Chrome coated brass trunk
- Available in BS, DIN, AFNOR, DISS and OHMEDA standards
- Max Suction Flow: 25L/min at-775 mbar
- Gas Consumption at max Scution : 60L/min

Gas Type	Without Adaptor						
Medical Air	FG53.01	FG53.02	FG53.03	FG53.04	FG53.05	FG53.07	FG53.06



Oxygen Therapy Device

Inspital Oxygen Therapy Device is appropriate to use in hospitals, emergency services and homecare units. This device is designed to adjust and control the oxygen flow.

- Chrome plated brass trunk
- High resistant polycarbonate humidifier bottle suitable for sterilization
- Maximum gas supply pressure : 200 bar
- Regulator Outlet Pressure : 3.5 - 4 bar
- Adjustable Flow : 0 - 15 L/min
- Pressure Gauge Range : 0 - 315 bar
- Sterilization Method : 121 °C

	Bull Nose	DIN	PIN INDEX
Model No	FM21.86	FM21.87	FM21.88



Oxygen Therapy Device Calibrated

- Maximum gas supply pressure : 200 bar
- Regulator Outlet Pressure : 3.5 - 4 bar
- Adjustable Flow : 0 - 15 L/min
- Pressure Gauge Range : 0 - 315 bar
- Dial flowmeter accuracy : $\pm 10\%$ read value or ± 0.5 L/min, which of the two greater
- Pressure reducer assy : Double stage with shutter system
- Flow setting data : 1013 mbar 23 °C
- Side gas outlet connection

	Bull Nose	DIN	PIN INDEX
Model No	FM21.69	FM21.79	FM21.89



Oxygen Therapy Device

Inspital Oxygen Therapy Device is appropriate to use in hospitals, emergency services and homecare units. This device is designed to adjust and control the oxygen flow.

- Chrome plated brass trunk
- High resistant polycarbonate humidifier bottle suitable for sterilization
- Maximum gas supply pressure : 200 bar
- Regulator Outlet Pressure : 3.5 - 4 bar
- Adjustable Flow : 0 - 15 L/min
- Pressure Gauge Range : 0 - 315 bar

	Bull Nose	DIN	PIN INDEX
Model No	FM21.96	FM21.97	FM21.98



Laboratory Series Stainless

- Line groups with body valve
- Inlet pressure : 0 - 40 bar
- Outlet Connection : R 3/8"
- Adjustable Pressure : 0-10 bar & Argon 1,5 bar
- Stainles diaphragm

Model No	Gas type	Gas flow	Inlet Connetion
GZ70.80	Oxygen	70 m ³ /h	R 1/4 NPT
GZ70.81	Nitrogen	70 m ³ /h	R 1/4 NPT
GZ70.82	N2O	70 m ³ /h	R 1/4 NPT
GZ70.83	Argon 1,5 bar	15 m ³ /h	R 1/4 NPT
GZ70.84	CO2	12 m ³ /h	R 1/4 NPT
GZ70.85	Helium	40 m ³ /h	R 1/4 NPT
GZ70.86	Hydrogen	55 m ³ /h	R 1/4 NPT
GZ70.87	Dyr Air	15 m ³ /h	R 1/4 NPT
GZ70.88	Mixed	60 m ³ /h	R 1/4 NPT



Pressure Regulators

- Double stage stainless
- Inlet pressure : 0 - 230 bar
- Outlet Connection : R 3/8"
- Adjustable Pressure : 0-10 bar Argon 1,5 bar
- Stainles diaphragm,

Single Model	Double Model	Gas type	Gas flow	Inlet Connetion
GZ70.60	GZ70.70	Oxygen	30 m ³ /h	R 3/8"
GZ70.61	GZ70.71	Nitrogen	30 m ³ /h	R 5/8" Inner
GZ70.62	GZ70.72	Argon	30 m ³ /h	R 5/8" Inner
GZ70.63	GZ70.73	CO2	11 m ³ /h	W21, 80X1/14
GZ70.64	GZ70.74	Helium	70 m ³ /h	R 5/8" Inner
GZ70.65	GZ70.75	Hydrogen	90 m ³ /h	W21, 80X1/14 Left
GZ70.66	GZ70.76	Dyr Air	30 m ³ /h	R 3/8"
GZ70.67	GZ70.77	N2O	30 m ³ /h	R 3/8"

Ventilator Regulators

Design to use with ventilator and direct oxygen supply at emergency, ICU and ambulances.

- Maximum gas supply pressure : 200 bar
- Regulator Outlet Pressure : 3.5 - 4 bar
- Pressure Gauge Range : 0 - 315 bar



	Bull Nose	DIN	PIN INDEX
Model No	FM21.91	FM21.92	FM21.93



Reusable Canister

Model No	Explanation
AT20.01	Canister, 1 L
AT20.02	Canister, 2 L
AT20.03	Canister, 3 L
AT20.04	Reusable lid

- Suitable for high vacuum applications
- New generation easy to use & hygienic system
- Antibacterial & hydrophobic self-sealing filter for extra safety
- Easy connection to central vacuum system



Model No	Explanation
AT20.10	Suction Liner, 1 L
AT20.20	Suction Liner, 2 L
AT20.30	Suction Liner, 3 L
AT20.11	Suction Liner With Antifoam, 1 L
AT20.22	Suction Liner With Antifoam, 2 L
AT20.33	Suction Liner With Antifoam, 3 L
AT20.91	Suction Liner With Solidifying Agents, 1 L
AT20.92	Suction Liner With Solidifying Agents, 2 L
AT20.93	Suction Liner With Solidifying Agents, 3 L

Suction Liner

- No contact with patient.
- Liner and lid are made of durable plastic.
- Liners are flexible
- In bags, optionally, disinfectant, foam inhibitor and Solidifying agents are available.

This system mixes simplicity and practicality, guaranteeing great safety from contamination for operators, for the suction plants and for the environment, thanks to the use of the latest manufacturing technologies and of absolutely reliable materials. The containers are made in three sizes, to be used according to the effective requirements about the volumes expected to be suctioned, and they are manufactured in two distinct versions: LINER VERSION | made by a reusable support rigid container and a disposable collection system, consisting of a resistant bag hermetically welded to the cover; CANISTER VERSION | fully disposable system consisting of a rigid container and a lid to be hermetically coupled before the start of the suction.



Suction Liner Manometer Probe

- That allows to open and close to suction from top of suction liner.
- Manometer and without manometer options

Suction Accessories



Rail Attachment

Explanation	Model No
For 25 x 5 mm Rail	AT20.37



Silicone / PVC Tube

Explanation	Model No
8 x 14 mm (silicone)	AT20.47
6 x 11 mm (silicone)	AT20.46
8 x 12 mm (PVC)	AT20.44
10 x 14 mm (PVC)	AT20.45



Yankauer Tipped Hose

Explanation	Model No
1,8 Meter	AT20.40
Suction Cannula tip	AT20.41



Wall Attachment

Explanation	Model No
Wall Attachment	AT20.50



Vacuum Control Connector

Explanation	Model No
Control Connector	AT20.54



Tube Connector

Explanation	Model No
Non-Sterile	AT20.52



Suction Liner Manometer Probe

Explanation	Model No
Manometer	AT20.78
Without Manometer	AT20.79



Suction Cannula, Plastic

Explanation	Model No
Non-Sterile	AT20.55



Kapkon Connector

Explanation	Model No
Kapkon Connector	AT20.53

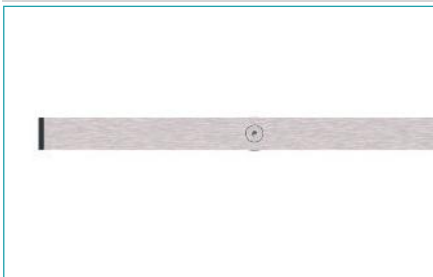

Rail

Explanation	Model No
1 meter	AT20.56

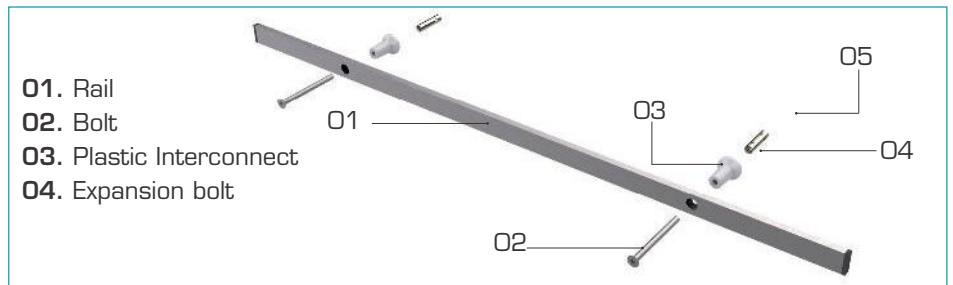

- 01. Rail
- 02. Bolt
- 03. Plastic Interconnect
- 04. Expansion bolt



AT20.75



AT20.75P

Central Vacuum System

- Integrated vacuum regulator
- Liner and lid are made of durable plastic.
- Trolley with 4 pcs vacuum jar capacity
- Polycarbonate, transparent vacuum jars with silicone hoses
- Sterilizable jars at 121°

Model No	Explanation
AT20.75	S/S frame, 4 port
AT20.75C	Powder coating frame, 4 port
AT20.75P	Powder coating frame, 1 port

1. **Patient port** - The patient port allows the suction of fluids and all its content safely
2. **Suction kit** - In-spital suction system has wide range of accessories for different suction applications
3. **Vacuum port** - This port connects to vacuum source coming from surgical suction device or central vacuum station line
4. **Filter** - In-spital suction liners are equipped with hydrophobic filter which work as an overflow valve and antibacterial barrier. It also keeps the electrosurgery smoke in the liner and protects the operation environment



Surgical Suction Jar

- Made of transparent polycarbonate material
- 1L and 2 L carrying capacity alternatives
- Sterilizable jars at 121° C
- Adapter for wall connection
- Integrated hydrophobic filter

Model No	Capacity
AT20.85	5 L
AT20.83	3 L
AT20.82	2 L



Analog System

Nurse Call Panel

The Nurse Call Panel is an intelligent unit with a microcontroller RTC and E². It can operate by itself or with a connection to a PC. Mode settings are available. It displays up to 5 calls at and displays the time, and temperature. The system communicates via RS485 modules. Other adjustments can be performed manually through a PC connection.

Model: GB22.70



Bedside Call Unit

The Bedside Call Unit is used patient rooms. There are backlit call and cancel buttons on the unit. In an emergency, a patient uses the call button to make an emergency call which appears as an alert on the Nurse Control Panel. Typical locations for this unit are on the walls of patient rooms and living areas as needed.

Model: GB22.76



Basic Handset

The Basic Handset allows the patient's condition to be reported quickly to the hospital staff in an emergency situation. It is easy to use and reinforced with auxiliary visuals. The device works through connection to the Bedside Call Unit. Easy-to-understand images indicate the functions of the buttons. Thanks to LEDs on the unit, the product is easily noticeable in the dark. These LEDs vary according to the last call made.

Model: GB22.72



Pull-cord Call Unit

The Pull-cord Call Unit is used in patient bathrooms or similar areas. There is a backlit cancel button and an emergency call pull-cord on the unit. In an emergency, a patient pulls the cord making an emergency call. This appears as a WC Emergency Call on the Nurse Control Panel. The system gives priority to WC Emergency calls and they appear before other calls.

Model: GB22.78



Over Door Light

The Over Door Light is located above the patient room door in the corridor. Its half-sphere shape makes it easily noticeable from any angle of view. If there is an emergency in the room, it can be seen clearly from the corridor. It can warn with three main colors, red, green, and blue, and combinations of these, depending on the call status of the room.

Model: GB22.80



Room Control Unit

The Room Control Unit is suitable for surface montage. Can support 4 beds, 1 WC, and 1 bath/shower by default. It can operate without external power supply.

Model: GB22.75



Light Control Unit

The Light Control Unit is a module that must be added to a system when control of room lighting/reading lamp through patient handsets is requested. This module supports up to 4 beds..

Model: GB22.82

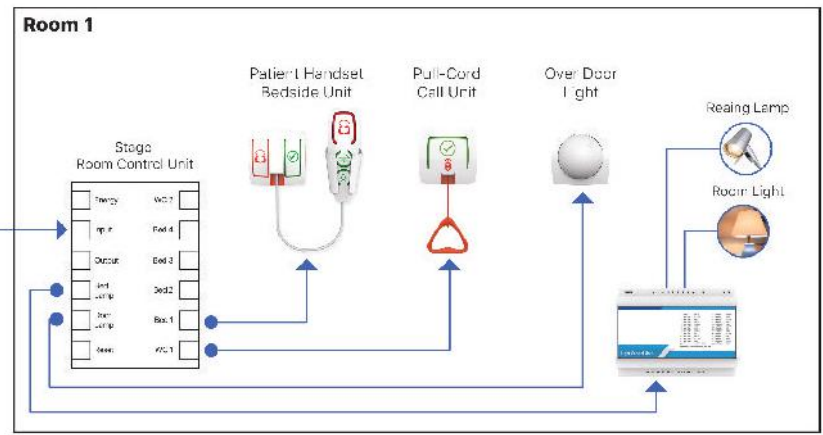
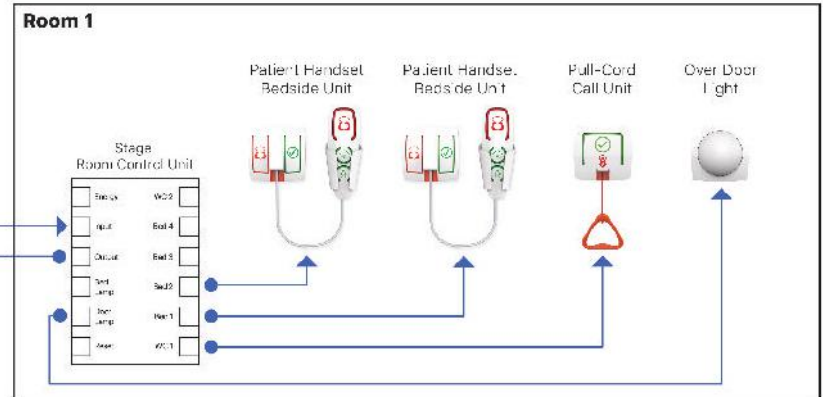
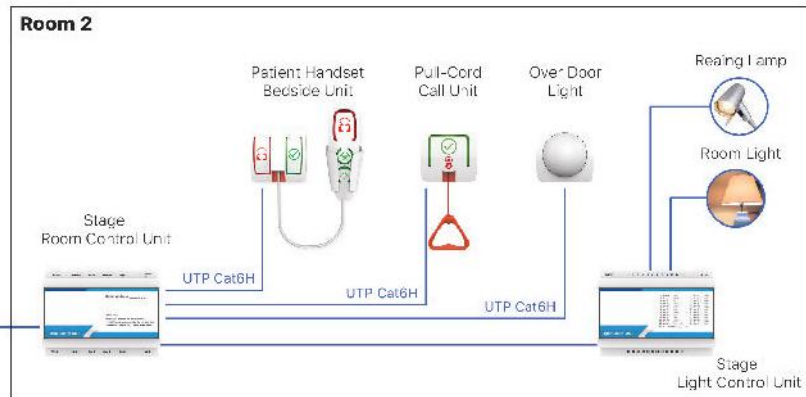
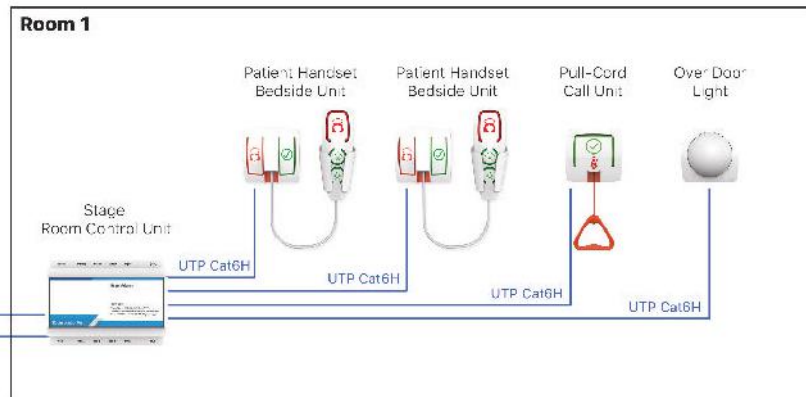



IP System

Room Control Unit 5"

This unit ensures communication between the Nurse Control Panel and the call buttons in patient rooms. The Room Control Unit is suitable for both flush and shallow montage. It features a 5" touchscreen and a built-in Mifare card reader. Optionally a basic task list can be accessible from the onscreen menu.

Model: GB22.83



7" Nurse Control Panel

The statuses of all working Room Control Units connected to the panel can be monitored actively. All errors and notifications shall be displayed on the information panel. Emergency codes, WC calls, and normal calls may be monitored. All processes passing through the system are logged.

Model: GB22.84



Pro Handset

The Pro Handset is designed to inform the staff of the patient's condition immediately.

- Easy to use
- Works through connection to Bedside Call Unit
- TV control option (Channel and Volume)
- EL lights allow visibility in the dark
- Function buttons help to control room lighting, reading lamp, window blinds, etc.

Model: GB22.85



Code Blue Unit

The Code Blue Unit is mounted on the wall as needed in the hospital. There are backlit call and code blue buttons on the unit. The call button may be pressed to initiate a nurse call which appears as an alert on the Nurse Control Panel. The code blue button may be pressed to start a Code Blue call. The same button can be configured as an assist call button.

Model: GB22.86



Over Door Light

The Over Door Light is located above the patient room door in the corridor. Its half-sphere shape makes it easily noticeable from any angle of view. If there is an emergency in the room, it can be seen clearly from the corridor. It can warn with three main colors, red, green, and blue, and combinations of these, depending on the call status of the room.

Model: GB22.81

Reporting and Management Server

The Over Door Light is located above the patient room door in the corridor. Its half-sphere shape makes it easily noticeable from any angle of view. If there is an emergency in the room, it can be seen clearly from the corridor. It can warn with three main colors, red, green, and blue, and combinations of these, depending on the call status of the room.

Model: GB22.87



System Block diagram

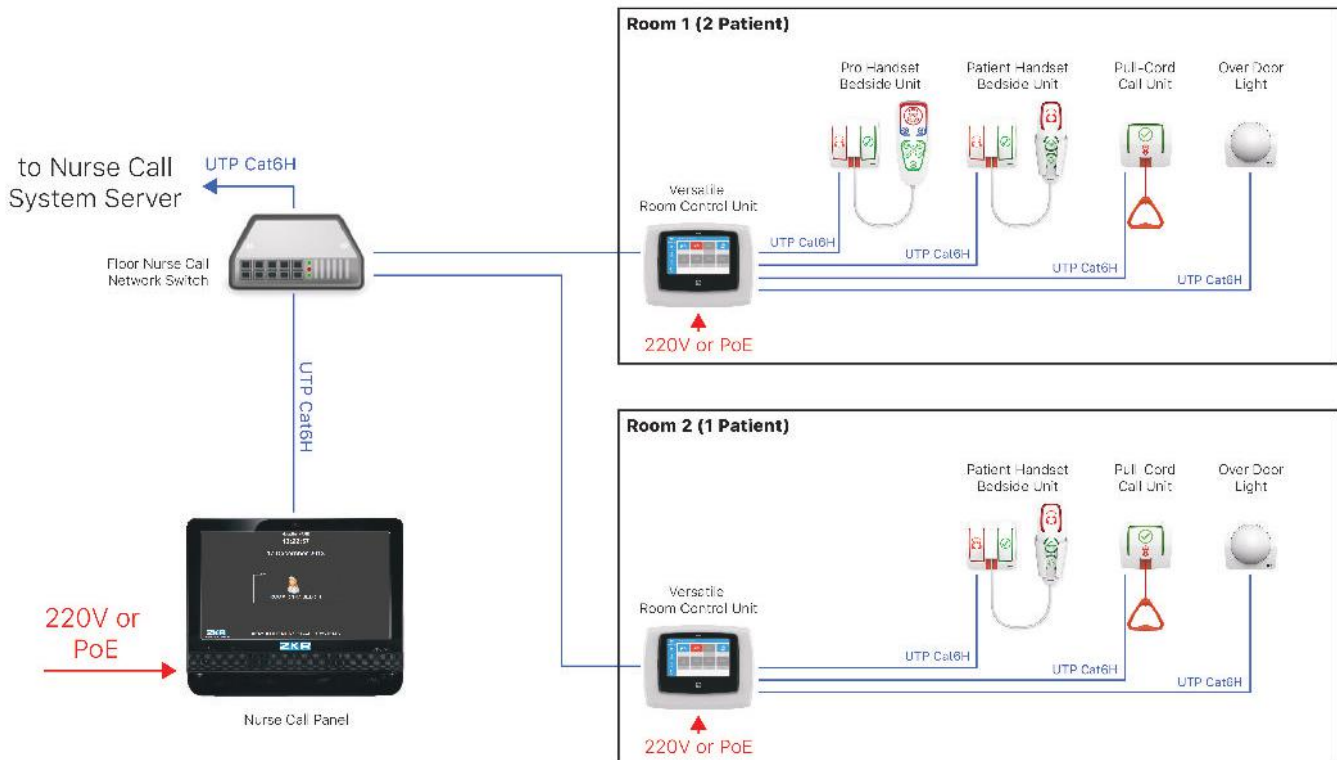



Wireless System Dot Matrix Panel

- Displays 4 calls in order of priority (others wait in queue)
- Adjustable 5 digits can show floor, room, bed number, etc.
- Color LEDs indicate call type
- Supports up to 64 beds
- Audible alerts according to call type

Model: GB22.71



Signal Repeater

It is used with the purpose of expanding the coverage area if the distance between the patient call units and the nurse panel is excessive. There is no restriction on the number of repeaters to be used in the environment. Requires external 5V Supply.

Model: GB22.74

Signal Repeater

It is used with the purpose of expanding the coverage area if the distance between the patient call units and the nurse panel is excessive. There is no restriction on the number of repeaters to be used in the environment. Requires external 5V Supply.

INSPIRAL Wireless Reporter Software

With the Reporter software, the calls made on system can be logged and reported. The software also doubles as a monitor for receiving calls, displaying calls in priority order with icons and colors indicating the call type: Nurse Call, Nurse Presence, WC Call, and Code Blue

- The software can be muted and unmuted with a single button. It features a Night Service toggle to forward all calls received to another panel.
- There is also a feature to set custom reminder alarms.
- All of the call logs and reminder logs can be viewed and filtered.
- Pager and Forwarding Panel settings can be configured.
- The program also allows names to be given to specific call points so that that name will appear in the logs and the call receiving screen

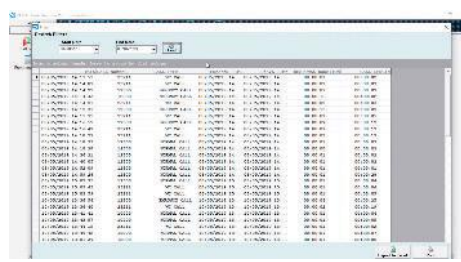
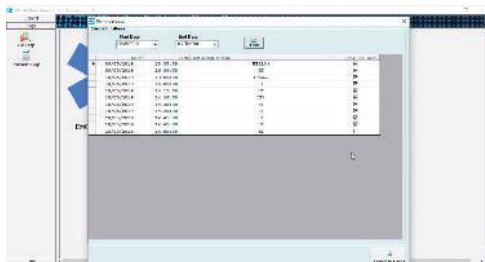

Pendants



Medical Gas Test & Commissioning Kit

- A complete set all in one box to carry out Test & Commissioning
- Includes Digital Pressure & Flow, AGSS Test & Commissioning, Male Anti Confusion NIST, Anti Confusion Probes and Standard Purging test kits
- In compliance with HTMO2-01 and relevant European Standards and all preceding standards.

Model:GZ75.01



Anti Confusion Probes

- Set of six stainless steel gas specific probes
- Gases include O₂, O₂/N₂O, N₂O, Air-4 Bar, Air-7 Bar, Vacuum
- Calibrated to BS 5682In compliance with HTMO2-01 and relevant European Standards and all preceding standards

Model:GZ75.02

Anti Confusion Probes

- Set of six or nine stainless steel gas specific NIST probes
- Gases include O₂, O₂/N₂O, N₂O, Air-4 Bar, Air-7 Bar, Vacuum
- Nine includes CO₂, N, HE02 (Carbon Dioxide, Nitrogen, Heliox)
- Calibrated and manufactured to current industry standards

Model:GZ75.03



Standard Particulate and Purging Kit

- 75/150Lpm flow rate jets
- Hydrophobic Membrane 47mm filter papers, 0.45(µm) pore size
- In compliance with HTMO2-01 and relevant European Standards and all preceding standards

Model:GZ75.04



Pressure Drop Test Gun

- Measures pressure losses at NIST or Outlet Point
- Lockable valve to prevent tampering
- Ideal to test at AVSU and Manifold points
- 20054D Digital Pressure Gauge or Conventional Analogue Gauge

Model:GZ75.05

Consultancy

We are on hand to offer advice throughout every project phase and take a flexible approach to your requirements. Our engineers provide you report of the compliance of your system with respect to HTM 02:01 or ISO 7396-1 and other relevant publications and relate deficiencies to the consequent risks to patients, users and equipment.

Planning, Design and Project Management

Our technically accomplished and experienced project experts take care of the planning, dimensioning, and design of the systems in line with the framework conditions at your hospital. In doing so, they ensure that all the project guidelines in relation to approval, quality, and risk management are observed. Even when certain specifications are tendered out, we always check whether the customer's requirements comply with statutory standards and regulations.

Through project management, we ensure clients always have a primary point of contact, keeping the client up to date with the project progress and coordinating forthcoming procedures.



Manufacturing of Equipment

It goes without saying that we only use components in our systems that have been approved in line with the relevant standards when we manufacture our high quality systems. We continuously develop our technology and safe products for high satisfaction of patients and their caregivers.

All plant and equipment are thoroughly tested before shipment to ensure minimal problems at the job site. All requirements for protection of materials during shipping are strictly observed.



Installation

The installation of medical gas systems requires highly specialized knowledge and tools. Inspital-certified installers who specialize in building medical gas systems are charged with this task.

Installations are invariably executed to the required HTM/EN or other International Standards, as specified and as performed in coordination with other services in an efficient and proper manner.

Finally, once the project has been completed and approved, we certify the entire set-up and ensure that you commission a tested and safe system.



Testing and Commissioning

Inspital inspects and approves the installed systems before they are handed over to the operator and commissioned.

After installation, Inspital Service carefully inspects all the system's functions in accordance with detailed approval protocols and inspection instructions. The system is only handed over once all the provisions have been met. As part of the handover, we give your employees detailed instructions on how to operate the entire system.



After Sales Service

We offer our customers comprehensive services for medical gas supply systems. Regular inspections by Inspital Service ensure that the systems are permanently ready for operation. Our service technicians are quickly on-site when repairs are needed.

INSPI TAL

**INSPI TAL Medical
Technology GmbH**

Kalkumer Str. 125

40468 Düsseldorf, GERMANY

Tel: +49 211 680 20 53-54

Fax: +49 211 680 20 55

www.inspital.com

info@inspital.com